

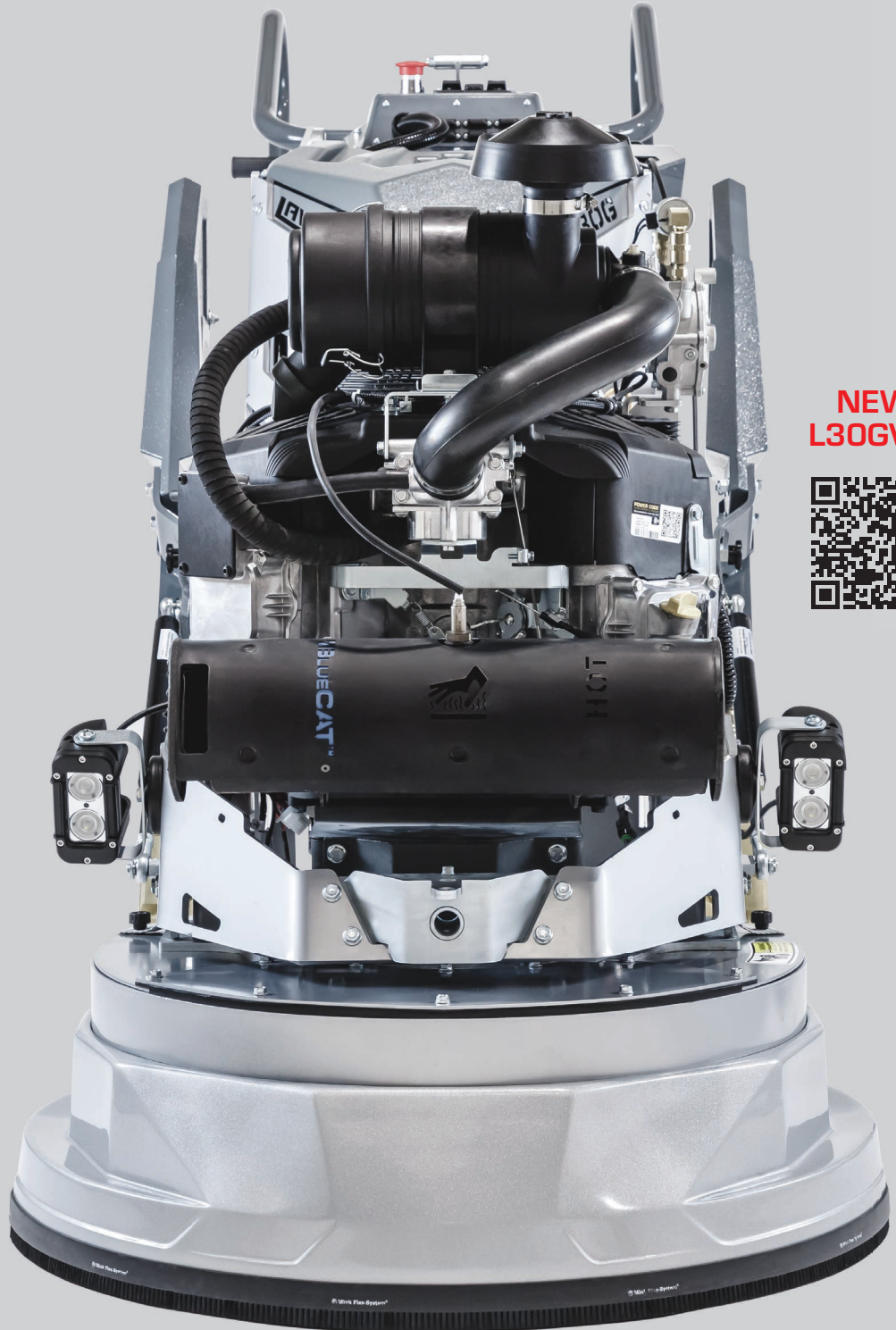

SUPERABRASIVE

2024



NEW!
L30GVS7



NEW



Since starting in 1987, Superabrasive has become a leading name in the concrete grinding and polishing industry. We strive to provide contractors with simple, efficient and user-friendly solutions that make their job easier.

In 2023, we released the seventh generation LAVINA Grinders - S7. The new machines boast an all-new design, from upgraded internals and new, dust proof grinding head to a new frame, weights and handlebar. And, we kept the prices the same, despite inflationary pressures, to offer the best value in the industry.

We're excited for 2024 as we plan to launch more S7 models, along with some new tooling and solutions. As always, we welcome the opportunity to speak with you and contribute to your success.



POLISHED CONCRETE

durable, cost effective, easy to maintain, sustainable, beautiful

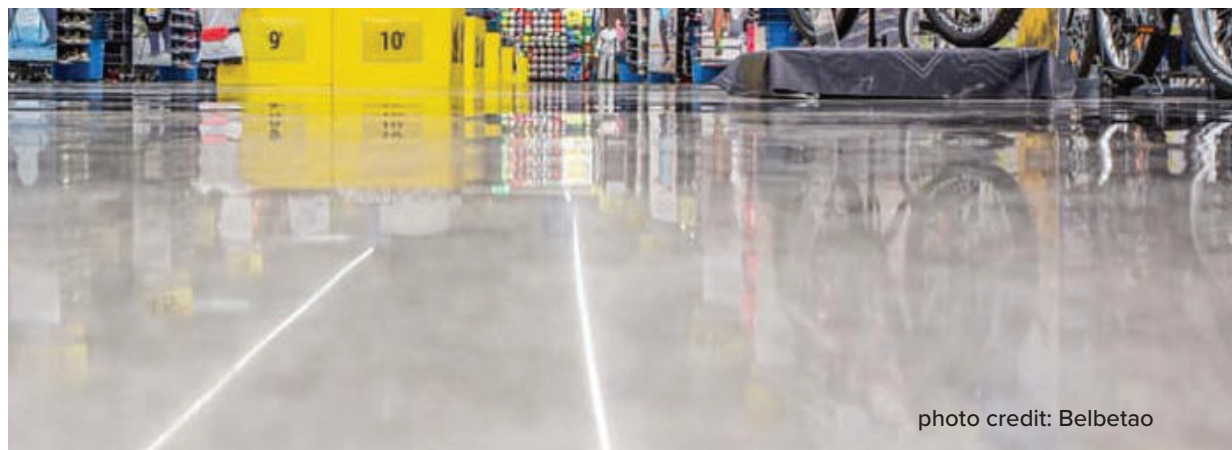
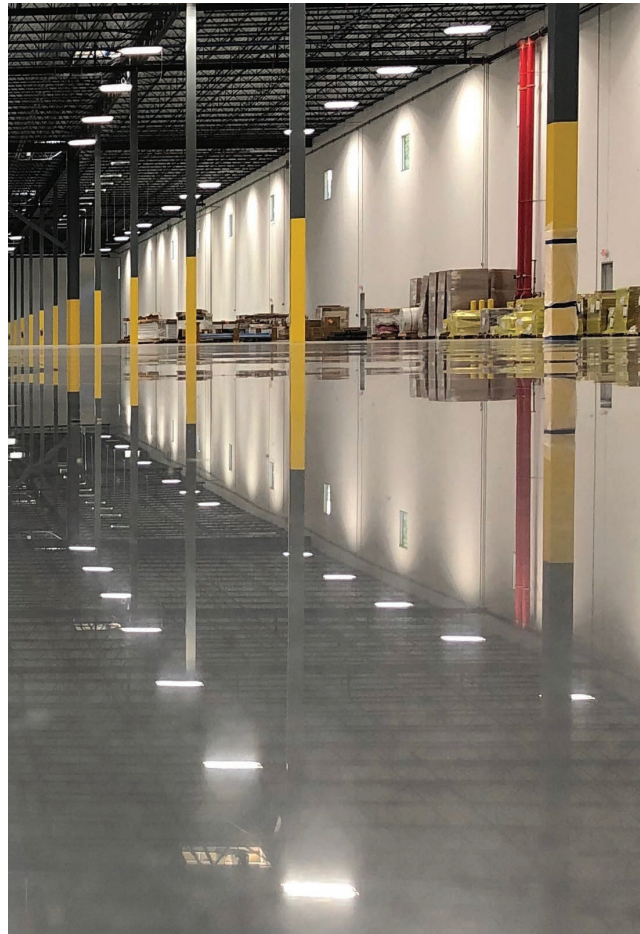
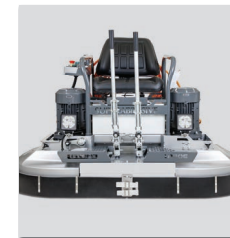

photo credit: Belbetao

PRODUCTS



POWER TROWELS:
PAGE 6



TROWEL SHINE SYSTEM:
PAGE 10



GRINDERS:
PAGE 14



LB36GTS POLISHER:
PAGE 30



DUST EXTRACTORS:
PAGE 32



AIR SCRUBBERS:
PAGE 38

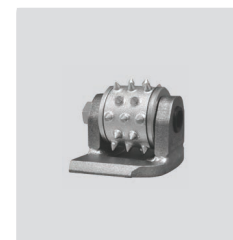

REMOVAL, PREP:
PAGE 40



GRINDING:
PAGE 42



TRANSITIONAL:
PAGE 48

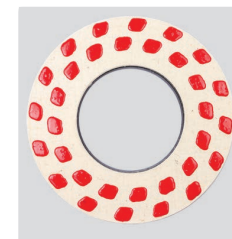

POLISHING:
PAGE 52

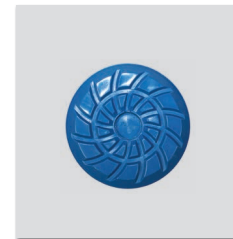

STONE SURFACES:
PAGE 60

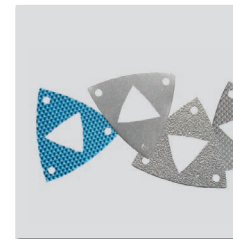

EDGE WORK:
PAGE 62



COUNTERTOPS:
PAGE 64

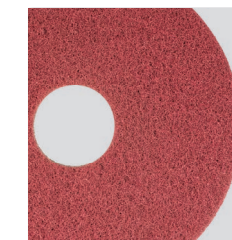

FLOOR MAINTENANCE:
PAGE 66



ADAPTER PLATES:
PAGE 72

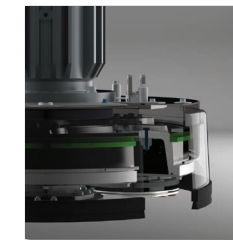

WARRANTY POLICY:
PAGE 74

LP36GE POWER TROWEL

powered by
KOHLER®



REENGINEERED FOR MAXIMUM UPTIME & PERFORMANCE.

For tooling options - see page 12

LP36GE FEATURES

- ✓ 80" working width with two 36" pans, and 4 x 13" tool holders on each pan.
- ✓ Free planetary drive
- ✓ KOHLER PCV 740 Propane Engine - more powerful, more fuel-efficient, and cleaner-burning
- ✓ Updated steering controls for easier operation and control
- ✓ Continuously variable transmission for optimum torque and speed
- ✓ Integrated wheel set and a manual crank system to lift the trowel for changing tools
- ✓ Transportation wheel
- ✓ Heavy-duty shroud with pins
- ✓ Emergency stop sensor on the seat
- ✓ LED lights

Propane Engine	Kohler Command Pro EFI PCV 740
Engine Capacity	747 cc / 45 cu.in., 24 hp / 17 kW 3600 min
Rotor RPM	0-185 rpm
Engine RPM	2000-3600 rpm
Path Width	80" / 2032 mm
Pan Diameter	2 x 36" / 2 x 915 mm
Tool Holders (total)	8 x 13.2" / 8 x 335 mm
Blades per Rotor	4
Propane Tank Capacity	33.5 lbs / 15.2 kg
Lifting (with manual jack)	7.9" / 200 mm
Weight (with pans)	1424 lbs / 646 kg
Machine Size L x W x H	82 x 41 x 61 in 208 x 104 x 162 cm



LP30E POWER TROWEL

electric model

Offered in 3 phase,
220V or 480V.

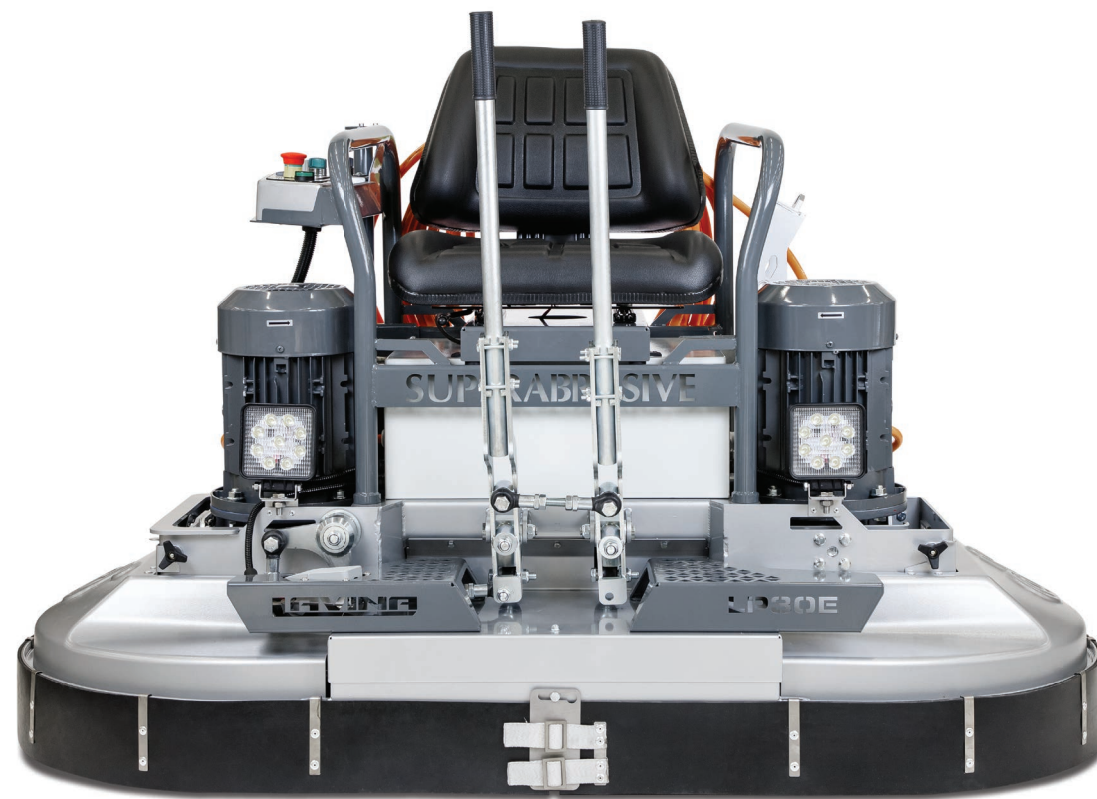

BIG PRODUCTIVITY IN A SMALL PACKAGE.

For tooling options - see page 12

LP30E FEATURES

- ✓ 61” working width with two 30” pans with 4 x 9” tool holders on each pan.
- ✓ Free planetary drive
- ✓ Easy to transport and move on a variety of projects - it goes through standard doors.
- ✓ Integrated wheel set and manual crank system to lift the trowel for changing blades and tools
- ✓ Transportation wheel
- ✓ Heavy-duty shroud with pins
- ✓ Emergency stop sensor on the seat
- ✓ LED lights

Motor Power	15 hp / 11 kW
Voltage (50-60 Hz) & Amperage	3 ph, 200-240V, 45A (max) Also, offered in 3 ph, 400-480V, 30A (max)
Rotor RPM	45-185 rpm
Path Width	61.2” / 1555 mm
Pan Diameter	2 x 30” / 2 x 765 mm
Tool Holders (total)	8 x 9” / 8 x 225 mm
Blades per Rotor	4
Water Feed	external connection
Lifting (manual jack)	6.5” / 165 mm
Cable Length	57 ft / 17.4 m
Weight	762 lbs / 345 kg
Machine Size L x W x H	63 x 32 x 67 in 162 x 84 x 123 cm

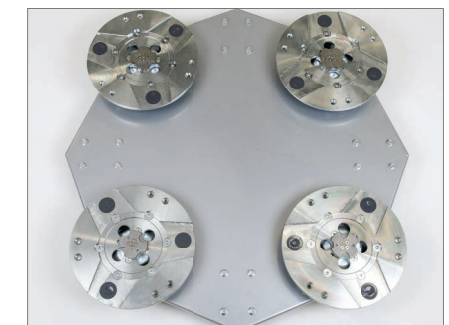

TROWEL SHINE

POWER TROWEL CONCRETE POLISHING SYSTEM

**TRANSFORM ANY POWER TROWEL
INTO A PLANETARY GRINDING AND POLISHING MACHINE**

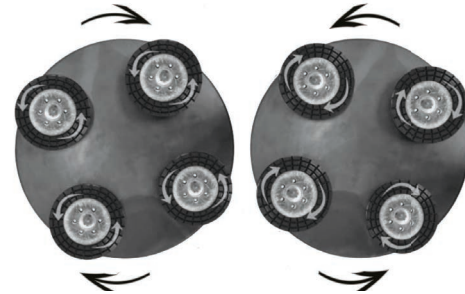

**THE FASTEST & MOST
COST-EFFICIENT POLISHING
SOLUTION FOR LARGE
INDUSTRIAL PROJECTS.**

**INCREDIBLY HIGH
PRODUCTIVITY - OVER
10,000 SF/HR PER GRIT.**

**MINIMUM START-UP COST
FOR TROWEL OWNERS WHO
WANT TO ADD POLISHING
SERVICES.**



TROWEL SHINE® SYSTEM

TOOL HOLDERS

13.2" / 335MM, #A80.00.00
Metal plate with Quick Change



10.63" / 335MM, #P02-FP-10,63
Foam plate with velcro attachment

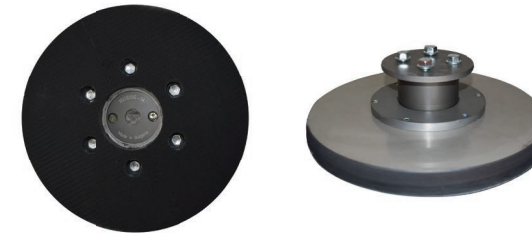

**FREE SPINNING HEADS AND
FREE PLANETARY DRIVE.**

**EASY TOOL CHANGES
WITH LAVINA TOOLS.**

**ENCAPSULATED BEARINGS,
NO NEED FOR PERIODIC
REGREASING OR INSPECTION.**

POPULAR TROWEL SHINE SET-UPS:

**36" / 900MM
4 X 13.2" HEADS**

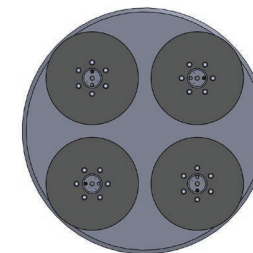

**48" / 1200MM
4 X 13.2" HEADS**

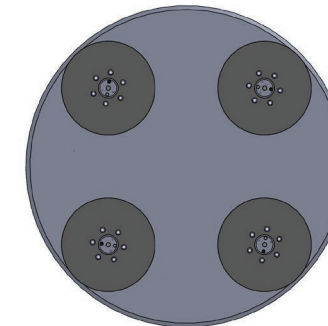

**48" / 1200MM
5 X 13.2" HEADS**

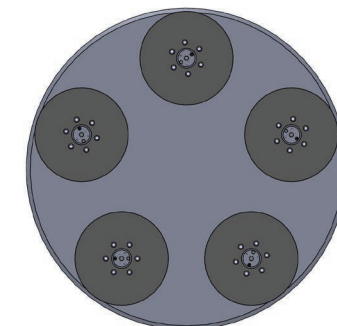

You can order trowel pans with pre-installed tool holders, or you can install the tool holders on your own trowel pans. We provide a drilling template with each tool holder. We recommend matching the number of tool holders to the number of trowel blades, and they should be installed symmetrically.

TOOLING OPTIONS

Trowel grinding and polishing is a **WET** process -a proper slurry management method should be used.

If grinding is necessary, use the SA-Metal Bond discs. Offered in 46, 70 and 120 grit. Don't forget to use the security plates (A64.00.01 for metals and A84.00.00 for 13" rings).

After SA Metals, use HD-Coppers 50 or 100 grit to remove scratches and transition to resins.

On flat floors you can start with Waffel Resin Pads, 50 grit. Use the **wet bond** Waffels for optimal tool life and performance.

Continue with Waffels 120 & 220 grit.

Densify after Waffels 220 grit.

Continue with Waffels 400 & 800 grit. After 400 grit you can switch to V-Harr or SupraShine HP pads, and continue up to the desired gloss level.

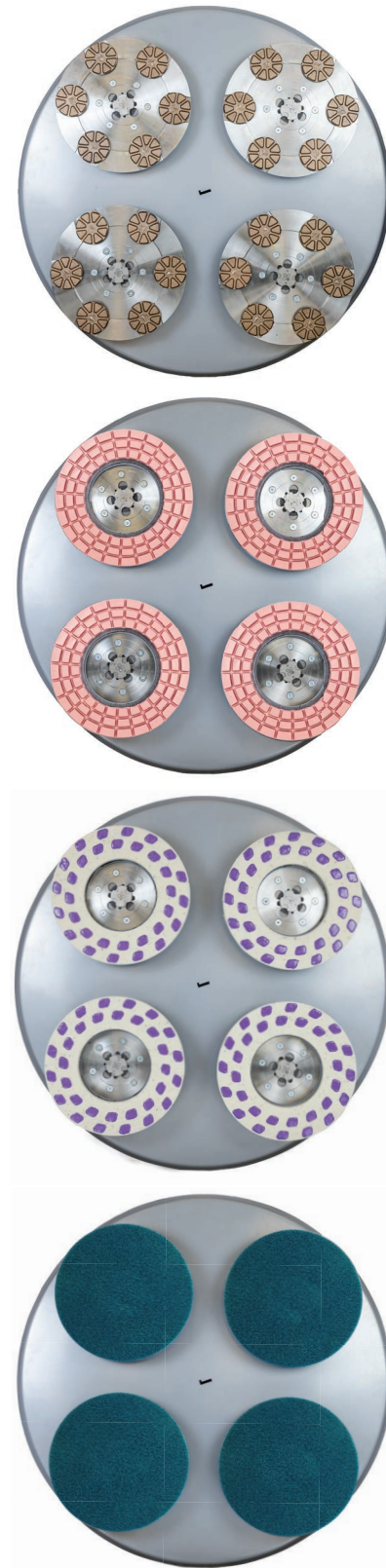

We now offer SupraShine pads in 36" and 48" size for use with trowel pans. They can be attached directly to the pans with velcro strips - no tool holders needed. Available in HD 220 and 400, and HP 800, 1800, 3500.



LAVINA S7 GRINDERS



S7- OUR BEST LAVINAS YET.

ALL-NEW FRAME DESIGN BETTER CONTROL, EASIER TOOL CHANGES

1. New weights for faster position change
2. Redesigned frame allowing easier tool changes - head angle during tool changes is greatly improved, compared to Elite models
3. New handle design – faster adjustability, more positions
4. Rubber bushing used at head attachment points - less vibrations for user
5. Water tank cap
6. Internal storage compartment

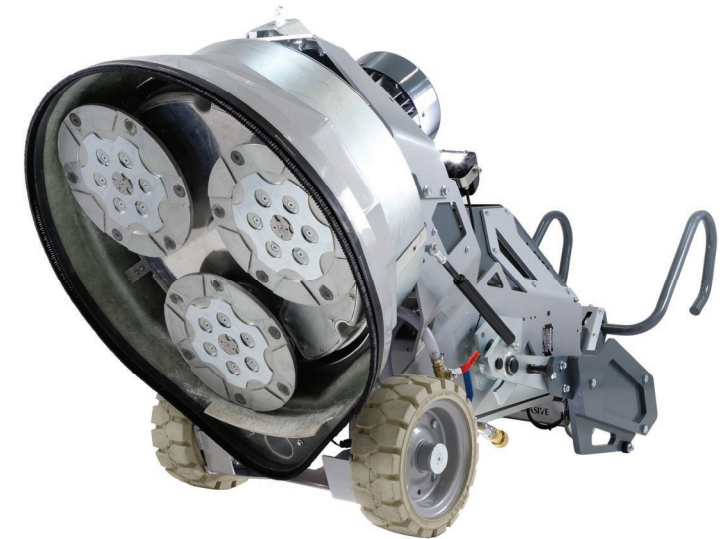

NEW SEALED & DUST-PROOF HEAD LONGER SERVICE LIFE, LESS MAINTENANCE

1. Completely redesigned chain-driven planetary drive with no chain tensioner
2. New stronger timing belt
3. Upgraded shafts, seals and bearings
4. New lighter timing pulleys for better power transmission
5. New two-piece aluminum main belt housing with belt inspection cover for longer belt life and less maintenance

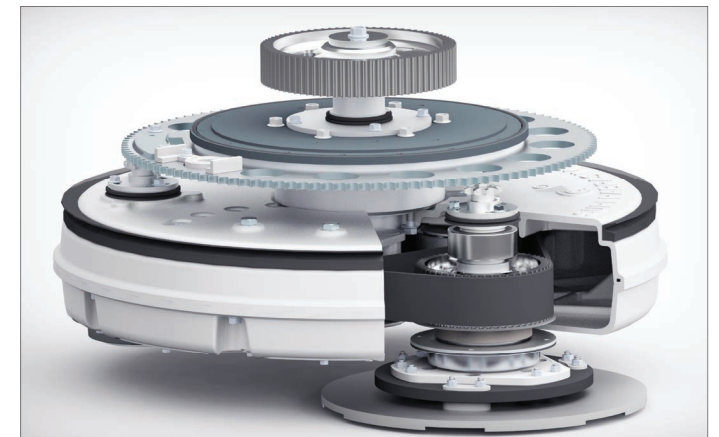



**HEAVY DUTY GRINDING
MADE EASY**

LAVINA® MACHINES

**NEW! L30GVS7
WITH VANGUARD 35HP**



**OPTION TO ADD WEIGHT
#A114.00.00 - 75 LBS**



Power up your productivity with the newest LAVINA Propane Grinder - L30GVS7. Equipped with a powerful Vanguard Engine, improved planetary drive and option to add more weight, this machine is designed for heavy-duty grinding and gets the job done with ease.

MODEL	L30GVS7
Propane Engine	VANGUARD
Engine Capacity	35 hp / 26 kW, 993 cc
Weight of Machine	926 lbs / 420 kg
Grinding Pressure	436-602 lbs / 198-273 kg
With extra weight (option)	706 lbs / 320 kg
Engine RPM	2000-3600 rpm
Tool Holder RPM	419-753 rpm
Tool Holder Rotation	Counterclockwise / Left
Tool Cutting Speed	7.3-13.1 m/s
Working Width	30.8 in / 783 mm
Tool Holder Diameter	3x13.2in / 3x335 mm
Vacuum Hose Port	Camlock E300
Water Feed	Tank or hose connection
Water Tank	5.2 gal / 20 L
Propane Tank	20 lbs / 9 kg
Machine Size L x W x H	86 x 32 x 46 in 218 x 82 x 116 cm



POWER TROWELS
FLOOR MACHINES
DUST EXTRACTORS
COATING REMOVAL
GRINDING
POLISHING
EDGES
COUNTERTOPS
MAINTENANCE
ACCESSORIES
TERMS

30" PROPANE S7



MODEL	L30GKS7
Propane Engine	KOHLER PCV 740
Engine Capacity	24 hp / 17.9 kW 747 cc, 45 cu.in.
Weight of Machine	926 lbs / 420 kg
Grinding Pressure	388-573 lbs 176-260 kg
Engine RPM	2000-3600 rpm
Tool Holder RPM	425-765 rpm
Tool Holder Rotation	Counterclockwise / Left
Tool Cutting Speed	7.3-13.1 m/s
Working Width	30.8 in / 783 mm
Tool Holder Diameter	3x13.2in / 3x335 mm
Vacuum Hose Port	Camlock E300
Water Feed	Tank or hose connection
Water Tank	5.2 gal / 20 L
Propane Tank	20 lbs / 9 kg
Machine Size L x W x H	86 x 32 x 46 in 218 x 82 x 116 cm

MODEL	L30GS7
Propane Engine	KAWASAKI FX600V
Engine Capacity	19 hp / 14.2 kW 603 cc, 36.8 cu.in.
Weight of Machine	908 lbs / 412 kg
Grinding Pressure	370-556 lbs 168-252 kg
Engine RPM	2000-3600 rpm
Tool Holder RPM	425-765 rpm
Tool Holder Rotation	Counterclockwise / Left
Tool Cutting Speed	7.3-13.1 m/s
Working Width	30.8 in / 783 mm
Tool Holder Diameter	3x13.2in / 3x335 mm
Vacuum Hose Port	Camlock E300
Water Feed	Tank or hose connection
Water Tank	5.2 gal / 20 L
Propane Tank	20 lbs / 9 kg
Machine Size L x W x H	86 x 32 x 46 in 218 x 82 x 116 cm

25" PROPANE S7

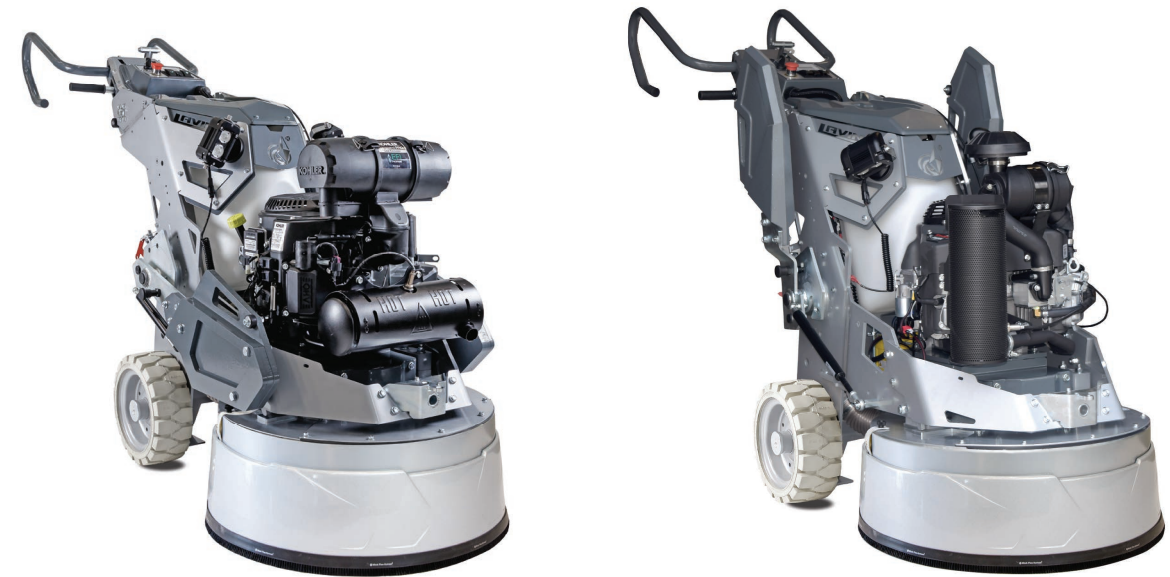

MODEL	L25GKS7
Propane Engine	KOHLER PCV 740
Engine Capacity	24 hp / 17.9 kW 747 cc, 45 cu.in.
Weight of Machine	901 lbs / 409 kg
Grinding Pressure	363-549 lbs 165-249 kg
Engine RPM	2000-3600 rpm
Tool Holder RPM	607-1100 rpm
Tool Holder Rotation	Counterclockwise / Left
Tool Cutting Speed	7.3-13.1 m/s
Working Width	26.5 in / 673 mm
Tool Holder Diameter	3x9 in / 3x225 mm
Vacuum Hose Port	Camlock E250
Water Feed	Tank or hose connection
Water Tank	5.2 gal / 20 L
Propane Tank	20 lbs / 9 kg
Machine Size L x W x H	84 x 29 x 46 in 214 x 72 x 116 cm

MODEL	L25GS7
Propane Engine	KAWASAKI FX600V
Engine Capacity	19 hp / 14.2 kW 603 cc, 36.8 cu.in.
Weight of Machine	884 lbs / 401 kg
Grinding Pressure	346-531 lbs 157-241 kg
Engine RPM	2000-3600 rpm
Tool Holder RPM	607-1100 rpm
Tool Holder Rotation	Counterclockwise / Left
Tool Cutting Speed	7.3-13.1 m/s
Working Width	26.5 in / 673 mm
Tool Holder Diameter	3x9 in / 3x225 mm
Vacuum Hose Port	Camlock E250
Water Feed	Tank or hose connection
Water Tank	5.2 gal / 20 L
Propane Tank	20 lbs / 9 kg
Machine Size L x W x H	84 x 29 x 46 in 214 x 72 x 116 cm

30" ELECTRIC S7



MODEL	L30S7
Power	15 hp / 11 kW
Voltage (50-60 Hz) Amperage (max)	3 phase, 200-240V 45 Amp
High Voltage Version	3 phase, 400-480V, 30A
Weight of Machine	908 lbs / 412 kg
Grinding Pressure	366-551 lbs 166-250 kg
Tool Holder RPM	400-765 rpm
Tool Holder Rotation	Counterclockwise / Left
Tool Cutting Speed	7-13.5 m/s
Working Width	30.8 in / 783 mm
Tool Holder Diameter	3x13.2 in / 3x335 mm
Vacuum Hose Port	Camlock E300
Water Feed	Tank or hose connection
Water Tank	5.2 gal / 20 L
Cable Length	57 ft / 17.4 m
Machine Size L x W x H	85 x 32 x 46 in 216 x 82 x 116 cm

EUROPEAN MODEL 
L30ES7
 3 phase, 380-400V, 30A

25" ELECTRIC S7

S7 Grinders have counterclockwise rotation of the heads.



MODEL	L25LS7
Power	15 hp / 11 kW
Voltage (50-60 Hz) Amperage (max)	3 phase, 200-240V 45 Amp
High Voltage Version	3 phase, 400-480V, 30A
Weight of Machine	884 lbs / 400 kg
Grinding Pressure	342-520 lbs 155-240 kg
Tool Holder RPM	400-1100 rpm
Tool Holder Rotation	Counterclockwise / Left
Tool Cutting Speed	4-14 m/s
Working Width	26.5 in / 673 mm
Tool Holder Diameter	3x9 in / 3x225 mm
Vacuum Hose Port	Camlock E250
Water Feed	Tank or hose connection
Water Tank	5.2 gal / 20 L
Cable Length	57 ft / 17.4 m
Machine Size L x W x H	84 x 29 x 46 in 212 x 72 x 116 cm

EUROPEAN MODEL 
L25LES7
 3 phase, 380-400V, 30A

MODEL	L25S7
Power	10 hp / 7.5 kW
Voltage (50-60 Hz) Amperage (max)	1 or 3 phase, 200-240V 30 Amp
High Voltage Version	n/a
Weight of Machine	871 lbs / 395 kg
Grinding Pressure	329-514 lbs 149-233 kg
Tool Holder RPM	400-1100 rpm
Tool Holder Rotation	Counterclockwise / Left
Tool Cutting Speed	4-14 m/s
Working Width	26.5 in / 673 mm
Tool Holder Diameter	3x9 in / 3x225 mm
Vacuum Hose Port	Camlock E250
Water Feed	Tank or hose connection
Water Tank	5.2 gal / 20 L
Cable Length	57 ft / 17.4 m
Machine Size L x W x H	84 x 29 x 46 in 212 x 72 x 116 cm

EUROPEAN MODEL 
L25ES7
 3 phase, 380-400V, 15A

REMOTE-CONTROLLED GRINDERS, ELITE SERIES



INTELLIGENT REMOTE CONTROL

Super light and easy to use RC with ergonomic rubber grip provides precise control over the machine, more consistent finish and less operator fatigue.



LAVINA RC GRINDERS CAN BE USED IN SELF-PROPELLED AND MANUAL MODE

INTUITIVE TOUCHSCREEN PANEL / HMI

Provides operating information and implements operator's instructions. HMI functions include:

- power supply and power consumption
- machine load and hours worked
- tool holder rpm, tool input, speed feed rate
- maintenance reminders
- password activation
- menu settings in different languages.

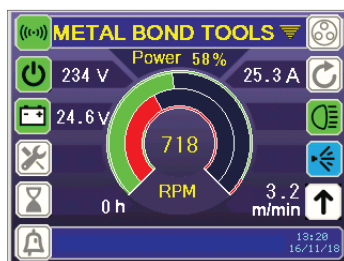

L3213REB *Also in 3ph, 380-480V, 32A

Power	20 HP / 15 KW
Voltage (50/60 Hz)	3ph x 200-240V
Amperage (max)	60 Amp
Dedicated Breaker	60 Amp
Generator Recommendation	45 KW

Weight of Machine	1607 lbs / 729 kg
Grinding Pressure	552-858.7 lbs / 250.5-389.5 kg

Attachment Speed	400-650 rpm
Working Width	32in / 814mm
Tool Holder Diameter	3x13.2in / 3x335mm

Vacuum Hose Port	Camlock E300
Water Feed	Tank or hose connection
Water Tank	12gal / 46L
Cable Length	57 ft / 17.4 m
AMG Battery	12 V/2x7 AH
RC Battery (rechargeable)	AA 1.2V

Machine Size	97x34x52 in / 246x86x130 cm
Crate Size	63x37x63 in / 160x95x160 cm

EUROPEAN MODEL 
L3213REUB
 15 kW, 3 phase 380-400V, 32 Amp



L25REB

Power	10 HP / 7.5 KW
Voltage (50-60 Hz)	1 or 3ph x 200-240V
Amperage (max)	30 Amp
Dedicated Breaker	30 Amp
Generator Recommendation	22.5 KW

Weight of Machine	983 lbs / 446 kg
Grinding Pressure	364-436 lbs / 165-198 kg

Attachment Speed	300-1100 rpm
Working Width	25in / 655mm
Tool Holder Diameter	3x9in / 3x225mm

Vacuum Hose Port	Camlock E250
Water Feed	Tank or hose connection
Water Tank	5.2gal / 20L
Cable Length	57 ft / 17.4 m
AMG Battery	12 V/2x7 AH
RC Battery (rechargeable)	AA 1.2V

Machine Size	76x28x47 in / 193x71x120 cm
Crate Size	58x33x57 in / 148x84x146 cm

EUROPEAN MODEL 
L25REUB
 7.5 kW, 3 phase 380-400V, 15 Amp

LAVINA® MACHINES



L3213EB *Also in 3ph, 380-480V, 32A

Power	20 HP / 15 KW
Voltage (50/60 Hz)*	3ph x 200-240V
Amperage (max)	60 Amp
Dedicated Breaker	60 Amp
Generator Recommendation	45 KW

Weight of Machine	1455 lbs / 660 kg
Grinding Pressure	562-878 lbs / 255-398.5 kg

Attachment Speed	400-650 rpm
Working Width	32in / 814mm
Tool Holder Diameter	3x13.2in / 3x335mm

Vacuum Hose Port	Camlock E300
Water Feed	Tank or hose connection
Water Tank	12 gal / 46 L
Cable Length	57 ft / 17.4 m

Machine Size L x W x H	100x34x52 in / 254x86x132 cm
Crate size L x W x H	63x37x63 in / 160x95x160 cm

EUROPEAN MODEL

L3213EUB

15 kW, 3 phase, 380-400 V, 32 Amp



LAVINA® MACHINES



L30LEB *Also in 3ph, 440-480V, 30A

Power	15 HP / 11 KW
Voltage (50-60 Hz)*	3ph x 200-240V
Amperage (max)	45 Amp
Dedicated Breaker	45 Amp
Generator Recommendation	33 KW

Weight of Machine	860 lbs / 390 kg
Grinding Pressure	465-545 lbs / 211-247 kg

Attachment Speed	300-1100 rpm
Working Width	30in / 765mm
Tool Holder Diameter	3x13.2in / 3x335mm

Vacuum Hose Port	Camlock E250
Water Feed	Tank or hose connection
Water Tank	5.2gal / 20L
Cable Length	57 ft / 17.4 m

Machine Size L x W x H	59x34x47 in / 150x81x120 cm
Crate Size L x W x H	58x33x57 in / 148x84x146 cm

EUROPEAN MODEL

L30LEUB

11 kW, 3 phase, 380-400V, 30 Amp



L25LEB *Also in 3ph, 440-480V, 30A

Power	15 HP / 11 KW
Voltage (50/60 Hz)	3ph x 200-240V
Amperage (max)	45 Amp
Dedicated Breaker	45 Amp
Generator Recommendation	33 KW

Weight of Machine	838 lbs / 380 kg
Grinding Pressure	443-522 lbs / 201-237 kg

Attachment Speed	300-1100 rpm
Working Width	25.8in / 655mm
Tool Holder Diameter	3x9in / 3x225mm

Vacuum Hose Port	Camlock E250
Water Feed	Tank or hose connection
Water Tank	5.2gal / 20L
Cable Length	57 ft / 17.4 m

Machine Size L x W x H	71x28x48 in / 180x71x122 cm
Crate Size L x W x H	58x33x57 in / 148x84x146 cm

EUROPEAN MODEL

L25LEUB

11 kW, 3 phase, 380-400 V, 30 Amp



L20NEB

Power	7.5 HP / 5.5 KW
Voltage (50/60 Hz)	1 or 3ph x 200-240V
Amperage (max)	30 Amp
Dedicated Breaker	30 Amp
Generator Recommendation	16.5 KW

Weight of Machine	584 lbs / 265 kg
Grinding Pressure	187-287lbs/85-130kg

Attachment Speed	300-1100 rpm
Working Width	20 in / 510 mm
Tool Holder Diameter	3 x 9in / 3 x 225mm

Vacuum Port	Camlock E250 or 2in hose
Water Feed	Tank or hose connection
Water Tank	5.2gal / 20L
Cable Length	57 ft / 17.4 m

Machine Size L x W x H	66 x 22 x 47 in 168 x 56 x 122 cm
Crate Size L x W x H	55 x 29 x 56 in 139 x 71 x 142 cm

EUROPEAN MODEL

L20NEUB 5.5 kW, 3 phase, 380-400 V, 15 Amp
L20NOEUB 5.5 kW, 1 phase, 200-240 V, 15 Amp



L20EB

Power	4 HP / 3 KW
Voltage (50/60 Hz)	1ph x 200-240V
Amperage (max)	14 Amp
Dedicated Breaker	20 Amp
Generator Recommendation	9 KW

Weight of Machine	443 lbs / 201 kg
Grinding Pressure	190 lbs / 86 kg

Attachment Speed	300-1100 rpm
Working Width	20 in / 510 mm
Tool Holder Diameter	3 x 9in / 3 x 225mm

Vacuum Port	Camlock E250 or 2in hose
Water Feed	Tank or hose connection
Water Tank	5.2gal / 20L
Cable Length	57 ft / 17.4 m

Machine Size L x W x H	66 x 22 x 48 in 168 x 56 x 122 cm
Crate Size L x W x H	55 x 29 x 56 in 139 x 71 x 140 cm

EUROPEAN MODEL

L20EUB
 3 kW, 1 phase, 200-240 V, 14 Amp



L16E *Also in 1 ph, 220V, 12A (L16EU)

Power	2.45 HP / 1.8 KW
Voltage (50/60 Hz)	1ph x 115V
Amperage (max)	16 Amp
Weight of Machine	216 lbs / 98 kg
Grinding Pressure	147.7 lbs / 67 kg
Weights (optional)	up to 2 x 17.6 lbs/ 8 kg

Attachment Speed	300-500 rpm
Working Width	16 in / 406 mm
Tool Holder Diameter	3 x 7 in / 3 x 178 mm
Vacuum Hose Port	2in / 51mm
Water Feed	no
Cable Length	no
Machine Size L x W x H	48 x 18 x 38 in 121 x 46 x 97 cm
Crate Size L x W x H	31 x 21 x 35 in 77 x 52 x 88 cm

EUROPEAN MODEL

L16EU, 300-900 rpm
 2.2 kW, 1 phase, 200-240 V, 12 Amp



L14E *Also in 1 ph, 220V, 12A (L14EU)

Power	2.45 HP / 1.8 KW
Voltage (50/60 Hz)	1ph x 115V
Amperage (max)	16 Amp
Weight of Machine	132 lbs / 60 kg
Grinding Pressure	53 lbs / 24 kg
Weights	no

Attachment Speed	400-1000 rpm
Working Width	13.2 in / 335 mm
Tool Holder Diameter	1 x 13.2in / 1 x 335mm
Vacuum Hose Port	2in / 51mm
Water Feed	no
Cable Length	no
Machine Size L x W x H	47 x 15 x 39 in 119 x 37 x 100 cm
Crate Size L x W x H	31x 21 x 35 in 77 x 52 x 88 cm

EUROPEAN MODEL

L14EU, 400-1000 rpm
 2.2 kW, 1 phase, 200-240 V, 12 Amp



REMOTE CONTROLLED



L38GREB

Propane Engine	Kawasaki FX1000V
Engine Capacity	999 cc / 61 cu.in.
Weight of Machine	1585 lbs / 719 kg
Grinding Pressure	603-898 lbs / 273.5-407.5 kg
Tool Holder RPM	416-750 rpm
Engine RPM	2000-3600 rpm
Working Width	36.5 in / 927 mm
Tool Holder Diameter	3x13.2in / 3x335 mm
Vacuum Hose Port	Camlock E300, 3 in
Water Feed	Tank or hose connection
Water Tank	12 gal / 46L
Propane Tank	33.5 lbs / 15.2 kg
Third Wheel	yes
AMG Battery	12 V / 2x7 AH
RC Battery (Rechargeable)	AA 1.2 V
Machine Size L x W x H	98 x 38 x 52 in / 250 x 97 x 130 cm
Crate Size L x W x H	69 x 40 x 63 in / 175 x 102 x 160 cm

L3213GEB

Propane Engine	Kawasaki FX1000V
Engine Capacity	999 cc / 61 cu.in.
Weight of Machine	1413 lbs / 641 kg
Grinding Pressure	645-922 lbs / 292-418 kg
Tool Holder RPM	425-765 rpm
Engine RPM	2000-3600 rpm
Working Width	32in / 814mm
Tool Holder Diameter	3x13.2in / 3x335 mm
Vacuum Hose Port	Camlock E300, 3 in
Water Feed	Tank or hose connection
Water Tank	12 gal / 46L
Propane Tank	33.5 lbs / 15.2 kg
Third Wheel	yes
Machine Size L x W x H	100 x 34 x 52 in / 254 x 86 x 132 cm
Crate Size L x W x H	63x37x63 in / 160x95x160 cm

L30GEB

Propane Engine	Kawasaki FX600V 19 hp / 14.2 kW
Engine Capacity	603 cc, 36.8 cu. in.
Weight of Machine	794 lbs / 360 kg
Grinding Pressure	448-529 lbs / 203-240 kg
Tool Holder RPM	570-1030 rpm
Engine RPM	2000-3600 rpm
Working Width	30in / 765mm
Tool Holder Diameter	3x13.2in / 3x335mm
Vacuum Hose Port	Camlock E250
Water Feed	Tank or hose connection
Water Tank	5.2gal / 20L
Propane Tank	20lbs / 9kg
Machine Size L x W x H	76.5 x 32 x 48 in / 194 x 81 x 121 cm
Crate Size L x W x H	58 x 33 x 57 in / 148 x 84 x 146 cm

L25GEB

Propane Engine	Kawasaki FX600V 19 hp / 14.2 kW
Engine Capacity	603 cc, 36.8 cu. in.
Weight of Machine	764 lbs / 346 kg
Grinding Pressure	418-489 lbs / 189-226 kg
Tool Holder RPM	570-1030 rpm
Engine RPM	2000-3600 rpm
Working Width	25in / 655mm
Tool Holder Diameter	3x9in / 3x225mm
Vacuum Hose Port	Camlock E250
Water Feed	Tank or hose connection
Water Tank	5.2gal / 20L
Propane Tank	20lbs / 9kg
Machine Size L x W x H	71 x 28 x 48 in / 180 x 71 x 122 cm
Crate Size L x W x H	58 x 33 x 57 in / 148 x 84 x 146 cm





36" PLANETARY POLISHER & BURNISHER

L20GE

Propane Engine	Kawasaki FS481V 18 hp / 13 kW
Engine Capacity	603 cc / 36.8 cu.in.
Weight of Machine	645 lbs / 292 kg
Grinding Pressure	267-364 lbs / 121-165 kg
Tool Holder RPM	610-1090 rpm
Engine RPM	2000-3600 rpm
Working Width	20in / 510mm
Tool Holder Diameter	3x9in / 3x225mm
Vacuum Hose Port	Camlock E250 or 2in
Water Feed	Tank or hose connection
Water Tank	5.2 gal / 20 L
Propane Tank	20 lbs / 9 kg
Machine Size L x W x H	66 x 22 x 48 in / 168 x 56 x 122 cm
Crate Size L x W x H	55 x 29 x 56 in / 139 x 71 x 142 cm

LB36G-S

Propane Engine Capacity	Kawasaki FS481V 18 hp / 13 kW
Engine Capacity	603 cc / 36.8 cu.in.
Weight of Machine	617 lbs / 280 kg
Tool Holder RPM	1666-3000 RPM
Engine RPM	2000-3600 RPM
Working Width	36in / 914.4mm
Tool Holder Diameter	3x14in / 3x356mm
Dust Collection System	vacuum turbine
Vacuum Bag	UB 101
Water Feed (with pump)	Front spray
Water Tank	5.2gal / 20L
Propane Tank	20lbs / 9kg
Machine Size L x W x H	79 x 37 x 44 in 200 x 95 x 112 cm
Crate size L x W x H	81 x 42 x 53 in 205 x 106 x 135cm

LAVINA ECO

**NEW INNOVATIVE TECHNOLOGY
TO DEEP CLEAN, RESTORE & MAINTAIN FLOORS**



DS Screens 220, 400, 600 (wet)
Densify concrete after 600 grit.

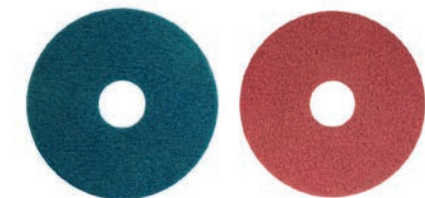

SupraShine HP 1800, 3500 (dry)
Seal floor after 1800 if needed.

- Simple and easy process provides deep cleaning, light grinding and polishing, where the scrubber can't do the job.
- Suitable for concrete, stone, terrazzo, and coated floors.
- Very low cost per square foot.
- Fast work speed - up to 10,000 sqf per day. Ideal for large commercial floors.
- Simple and quick staff training.

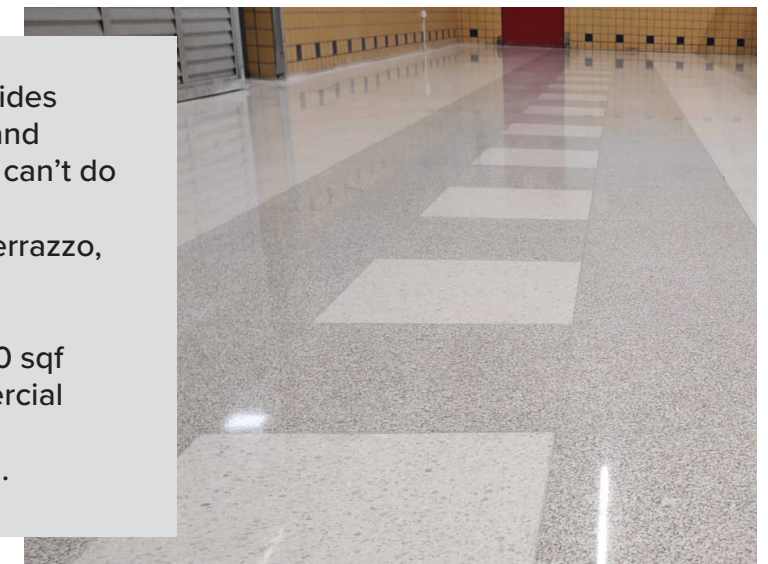

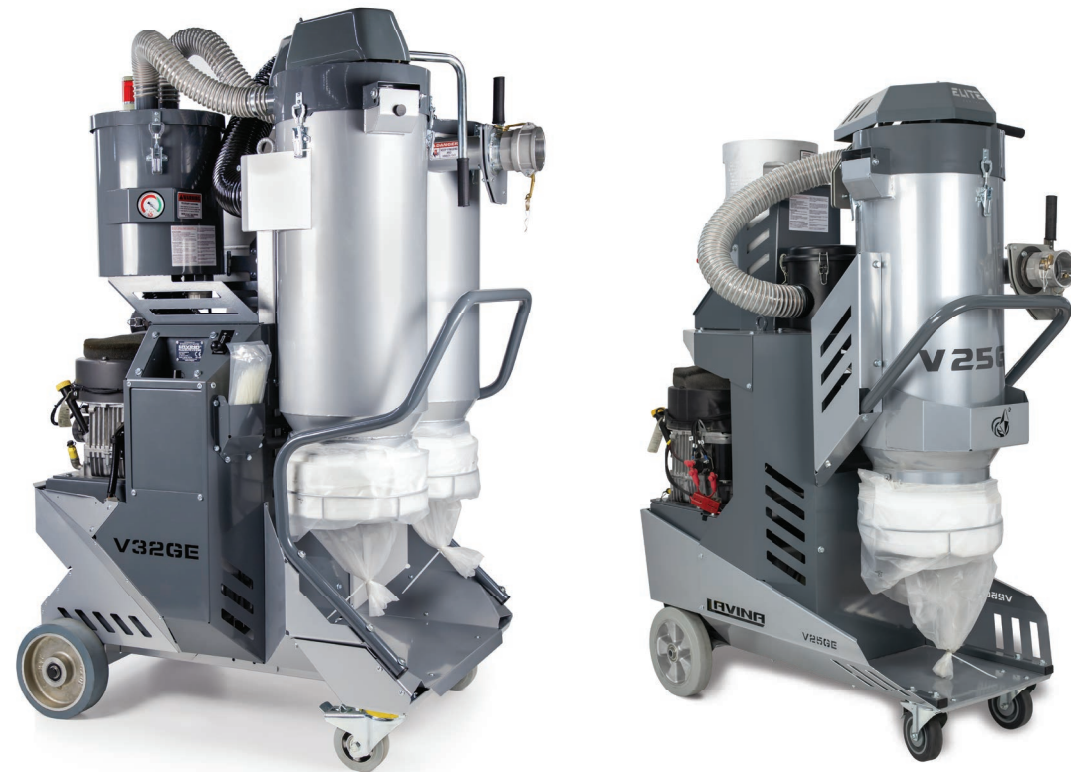

MODEL	V32GE	V25GE
Propane Engine	Kawasaki FX600V	Kawasaki FS481S
Engine Capacity	603 cc / 36.8 cu.in.	603 cc / 36.8 cu.in.
Propane Tank Capacity	20 lbs / 9 kg	20 lbs / 9 kg
Main Filter	Conical Filter	Conical Filter
Filter Surface Area	53.8 ft ² / 5 m ²	43 ft ² / 4 m ²
Filter Cleaning	Manual (opt. Auto)	Manual
Hepa Surface Area	43 ft ² / 4 m ²	21.5 ft ² / 2 m ²
Airflow (max)	470.9 cfm 800 m ³ /h	294 cfm 500 m ³ /h
Vacuum (max)	112.5 water lift 0.28 bar	120 water lift 0.3 bar
Longopac	yes	yes
Main Vacuum Hose	3 in x 32 ft 75 mm x 10 m	2.5 in x 32 ft 63 mm x 10 m
Hose for Wand	50mm x 6.6m 2 in x 21.3 ft	50mm x 6.6m 2 in x 21.3 ft
Dimensions L x W x H	51 x 31.5 x 70 in 130 x 80 x 178 cm	37 x 23 x 63 in 115 x 65 x 160 cm
Weight	730 lbs / 330kg	440 lbs / 200 kg



**FOUR-STAGE DUST COLLECTION FOR A
DRAMATIC INCREASE IN CLEANING EFFICIENCY.**

- ✓ Conical M class filter
- ✓ Hepa filter H13
- ✓ Option to upgrade to Automatic Cleaning



MODEL	V32E230	V32E480	V32EU
Motor	Turbine motor	Turbine motor	Turbine motor
Voltage	3 phase, 208V, 60 Hz	3 phase, 480V, 60 Hz	3 phase, 380V, 50 Hz
Amperage	30.4 Amp	17.5 Amp	16.9 Amp
Distribution Plug	55 Amp	32 Amp	32 Amp
Motor Power	11.5hp / 8.6kW	11.5hp / 8.6kW	10hp / 7.5kW
Main Filter	Conical Filter	Conical Filter	Conical Filter
Filter Surface	53.8 ft ² / 5 m ²	53.8 ft ² / 5 m ²	53.8 ft ² / 5 m ²
Filter Cleaning	Manual (opt. Auto)	Manual (opt. Auto)	Manual (opt. Auto)
Hepa Surface	43 ft ² / 4 m ²	43 ft ² / 4 m ²	43 ft ² / 4 m ²
Airflow (max)	490 cfm 840 m ³ /h	490 cfm 840 m ³ /h	447 cfm 760 m ³ /h
Vacuum (max)	112.5 water lift 0.28 bar	112.5 water lift 0.28 bar	112.5 water lift 0.28 bar
Longopac	yes	yes	yes
Main Vacuum Hose	3 in x 32 ft 75 mm x 10 m	3 in x 32 ft 75 mm x 10 m	3 in x 32 ft 75 mm x 10 m
Hose for Wand	2 in x 21.3 ft 50 mm x 6.6m	2 in x 21.3 ft 50 mm x 6.6m	2 in x 21.3 ft 50mm x 6.6m
Dimensions	51 x 32 x 70 in 130 x 80 x 178 cm	51 x 32 x 70 in 130 x 80 x 178 cm	51 x 32 x 70 in 130 x 80 x 178 cm
Weight	620 lbs / 280kg	620 lbs / 280kg	620 lbs / 280kg

LAVINA® DUST EXTRACTORS



- ✓ Improved conical filter made of the industry-best filter material with new seals
- ✓ Additional 3rd valve for dust release before and after filter cleaning without stopping the vacuum
- ✓ Easy access to the HEPA filter
- ✓ Completely metal construction with innovative design, smaller and lighter body for easier transportation

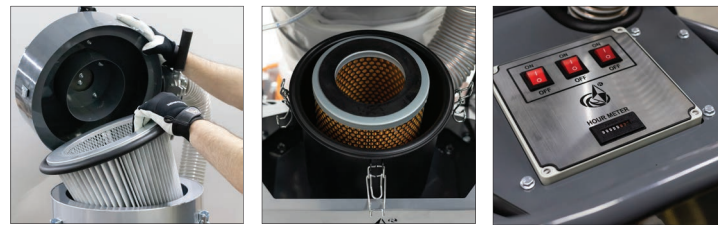

MODEL	V25E115	V25E230	V25EU
Motor	3 bypass motors	3 bypass motors	3 bypass motors
Voltage (50/60 hz)	1 phase, 115 V	1 phase, 230 V	1 phase, 230 V
Amperage	19.5 Amp	19.5 Amp	15 Amp
Motor Power	3.4 hp / 2.5 kW	4.9 hp / 3.6 kW	4.5 hp / 3.3 kW
Main Filter	Conical Filter	Conical Filter	Conical Filter
Filter Surface	43 ft ² / 4 m ²	43 ft ² / 4 m ²	43 ft ² / 4 m ²
Filter Cleaning	Manual	Manual	Manual
Hepa Surface	21.5 ft ² / 2 m ²	21.5 ft ² / 2 m ²	21.5 ft ² / 2 m ²
Airflow (max)	286 cfm 486 m ³ /h	386 cfm 656 m ³ /h	308.1 cfm 523 m ³ /h
Vacuum (max)	81 water lift 0.2 bar	100.4 water lift 0.25 bar	97.8 water lift 0.24 bar
Longopac	yes	yes	yes
Main Hose	2.5 in x 32 ft 63mm x 10m	2.5 in x 32 ft 63mm x 10m	2.5 in x 32 ft 63mm x 10m
Hose for Wand	2 in x 21.3 ft 50mm x 6.6m	2 in x 21.3 ft 50mm x 6.6m	2 in x 21.3 ft 50mm x 6.6m
Dimensions	36.5 x 23 x 63 in 93 x 59 x 160 cm	36.5 x 23 x 63 in 93 x 59 x 160 cm	36.5 x 23 x 63 in 93 x 59 x 160 cm
Weight	209 lbs / 95 kg	209 lbs/ 95 kg	209 lbs/ 95 kg

LAVINA® DUST EXTRACTORS



MODEL	V20E115	V20E230	V20EU
Motor	2 bypass motors	2 bypass motors	2 bypass motors
Voltage (50/60 hz)	1 phase, 115 V	1 phase, 230 V	1 phase, 230 V
Amperage	15.4 Amp	13 Amp	13 Amp
Motor Power	2.6 hp / 1.93 kW	3.3 hp / 2.4 kW	3.3 hp / 2.4 kW
Main Filter	Conical Filter	Conical Filter	Conical Filter
Filter Surface	32 ft ² / 3 m ²	32 ft ² / 3 m ²	32 ft ² / 3 m ²
Filter Cleaning	Manual	Manual	Manual
Hepa Surface	21.5 ft ² / 2 m ²	21.5 ft ² / 2 m ²	21.5 ft ² / 2 m ²
Airflow (max)	194 cfm 330 m ³ /h	257 cfm 437 m ³ /h	210 cfm 357 m ³ /h
Vacuum (max)	86.7 water lift 0.22 bar	100.4 water lift 0.25 bar	100.4 water lift 0.25 bar
Longopac	yes	yes	yes
Main Hose	2 in x 24 ft 50 mm x 7.5 m	2 in x 24 ft 50 mm x 7.5 m	2 in x 24 ft 50 mm x 7.5 m
Hose for Wand	n/a	n/a	n/a
Dimensions	33 x 23 x 55 in 83 x 59 x 139 cm	33 x 23 x 55 in 83 x 59 x 139 cm	33 x 23 x 55 in 83 x 59 x 139 cm
Weight	176 lbs/ 80 kg	176 lbs/ 80 kg	176 lbs/ 80 kg

NEW! V16E SLURRY VACUUM

- ✓ Can be used wet or dry.
- ✓ Offered in 115V & 230V.
- ✓ Automatic overflow shutoff.
- ✓ Stainless steel body.
- ✓ Washable hydrophobic filter.
- ✓ Optional accessory - Squeegee tool for slurry.

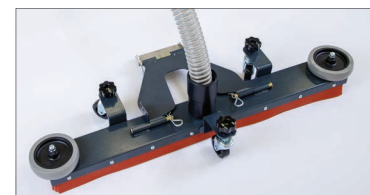

MODEL	V16E115	V16E230	V16EU
Motor	1.3 hp / 1 kW	1.6 hp / 1.2 kW	1.6 hp / 1.2 kW
Voltage (50/60 hz)	1 phase, 115V	1 phase, 230V	1 phase, 230V
Amperage	6.5 Amp	4.9 Amp	4.9 Amp
Filter & Filter Surface	Cylindrical 10.8 ft ² / 1 m ²	Cylindrical 10.8 ft ² / 1 m ²	Cylindrical 10.8 ft ² / 1 m ²
Airflow (max)	95 cfm 160 m ³ /h	103 cfm 175 m ³ /h	98 cfm 166 m ³ /h
Vacuum (max)	88 water lift 0.22 bar	88 water lift 0.22 bar	88 water lift 0.22 bar
Tank Capacity	13 gal / 50 l	13 gal / 50 l	13 gal / 50 l
Dimensions	26 x 20 x 43 in 65 x 50 x 110 cm	26 x 20 x 43 in 65 x 50 x 110 cm	26 x 20 x 43 in 65 x 50 x 110 cm
Weight	110 lbs / 50 kg	110 lbs / 50 kg	110 lbs / 50 kg

LAVINA ELITE PRE-SEPARATOR

- ✓ Works between the grinder and the vacuum to catch 95% of the dust before it reaches the vacuum.
- ✓ Extends vacuum filter life and reduces the need to clean and replace it.
- ✓ Compact design and light construction for easy transportation.



Longopac	yes
Main Vacuum Hose	3 in x 6.5 ft 75 mm x 2 m
Inlet	Camlock 3"
Outlet	Camlock 3"
Dimensions L x W x H	26 x 21 x 53 in 65 x 52 x 143 cm
Weight	121 lbs / 55 kg

Accessories for PSE
Camlock Connections:
1. 3"F to 2.5"M
2. 3"F to 2"M
3. 3"M to 2.5"F
4. 3"M to 2"F

FIND THE RIGHT DUST EXTRACTOR FOR YOUR GRINDER

MODEL	HEPA FILTER	EFFICIENCY	L14, L16	L21, L20, L20N	L25	L25L, L30L	L25G, L30G	L32, L32G	L38G
V16			X						
V20	1 HEPA, H13 CLASS	99.9% AT 0.3 MICRONS	X	X					
V25, 115V	1 HEPA, H13 CLASS	99.9% AT 0.3 MICRONS		X	X				
V25, 230V	1 HEPA, H13 CLASS	99.9% AT 0.3 MICRONS			X	X	X		
V25G	1 HEPA, H13 CLASS	99.9% AT 0.3 MICRONS			X	X	X		
V32, V32G	1 HEPA, H13 CLASS	99.9% AT 0.3 MICRONS					X	X	X

LAVINA AIR SCRUBBER



PORTABLE AIR FILTRATION SYSTEM FOR CLEANER AIR AND SAFER WORK ENVIRONMENT.

- ✓ Heavy-duty construction
- ✓ Easy to use and transport
- ✓ Large pre-filter area, plus Hepa filter
- ✓ Two-speed motor
- ✓ Orange light indicates clogged filter, Red light prompts to change the Hepa
- ✓ Quiet operation
- ✓ 10-inch air exhaust

Model	LA2000-115
Voltage	1 phase 115 V, 60 Hz
Amperage	3.6 / 4.8 Amp, Max. 12 Amp
IP (ingress protection)	22
Power (full speed)	0.8 HP / 600 W
Speed	1350 / 1680 rpm
Pre Filter Area	6.89 ft ² / 0.64 m ²
Hepa Classification	H13
HEPA Filter Area	113 ft ² / 10.5 m ²
Max Airflow	1177 CFM 2000 m ³ /h
Sound Level	60-67 db(A)
Dimensions L x W x H	27x17x31 in 69x43x79 cm
Weight	117 lbs / 53 kg



DIAMOND TOOLS

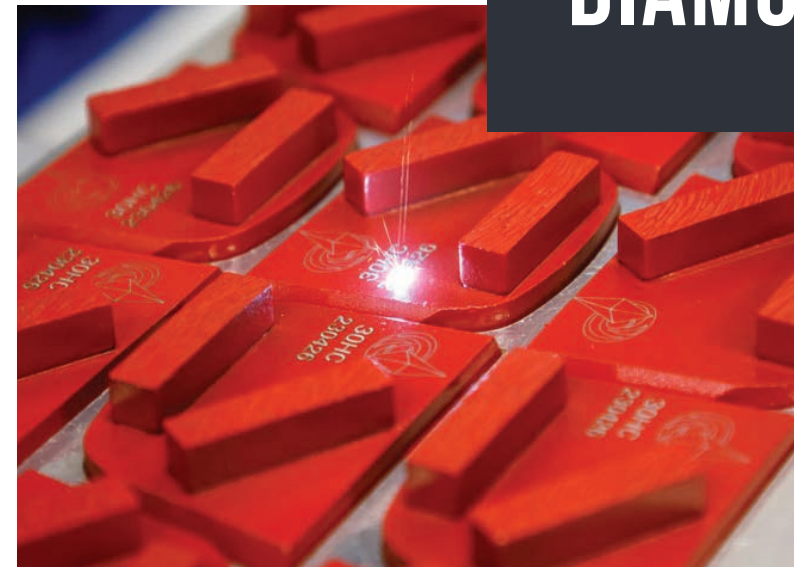

REMOVAL AND PREP

BUSH HAMMER TOOLS

Bush hammers are aggressive one-step method for stripping, cleaning and profiling concrete (CSP 3, 4 and 5) in preparation for epoxy and self-leveling or polymer overlays. The process is cost-effective, produces little airborne dust, and it doesn't micro fracture the surface. Always attach the QC security rings for safe operation with LAVINA grinders.

**RECOMMENDED RPM: 550-750 for electric machines;
1800-2100 for propane machines.**

Item Number	Description
X-BH-3	Quick Change BUSH HAMMERS, set of 3 pcs



CARBIDE SCRAPERS

Ideal for fast removal of thick topical coatings and glues, without damaging the concrete underneath and safe to use on floors that will be polished. They feature replaceable tungsten carbide blades.

Important! The scrapers are direction specific, and are offered in 2 styles - BLACK tools for machines with Right rotation of the grinding heads (all electric models except for 32" Elites), and BLUE tools for machines with Left rotation (all propane models and electric 32" Elites).

**RECOMMENDED RPM: 550-650 for electric machines;
1800-2100 for propane machines.**

Item Number	Description
X-HOLDER-CBL-19	Quick Change Carbide Scraper, Right (black)
X-HOLDER-CBL-19-L	Quick Change Carbide Scraper, Left (blue)
CBL-19	Square Carbide Blade (19mm)



REMOVAL AND PREP

PCD TOOLS

Designed for coating removal and prep for epoxy. PCD's with a metal button or sacrificial bars are designed for thin coating removal. PCD's without a metal button or sacrificial bars are designed for thick coating removal. They are very aggressive and leave a coarse profile on the floor.

- Use the BLACK PCDs for Lavina electric grinders, except for 32" Elites.
- Use the BLUE PCDs for Lavina propane grinders and electric 32" Elites.

**RECOMMENDED RPM: 550-650 for electric machines;
1800-2100 for propane machines.**



Item Number	Description
X-PCD-SB	Quick Change PCD tool with 2 PCD segments and sacrificial bars, Right (black)
X-PCD-SB-L	Quick Change PCD tool with 2 PCD segment and sac bars, Left (blue)
X1B-PCD2	Quick Change PCD tool with 2 PCD segments and a metal button, Right (black)
X1B-PCD2-L	Quick Change PCD tool with 2 PCD segments and a metal button, Left (blue)
X-PCD	Quick Change PCD tool with 2 PCD segments, Right (black)
X-PCD-L	Quick Change PCD tool with 2 PCD segments, Left (blue)
EPCD	Quick Change PCD tool with 2 PCD segments, Economy, Right (black)
EPCDL	Quick Change PCD tool with 2 PCD segments, Economy, Left (blue)
EPCDSB	Quick Change PCD tool with 2 PCD segments and sac bars, Economy, Right (black)
EPCDSBL	Quick Change PCD tool with 2 PCD segments and sac bars, Economy, Left (blue)



CONCRETE GRINDING

QUICK CHANGE METAL BOND TOOLS

Our Quick Change system features trapezoid style pads that easily slide in and out of the grinder heads, with no bolting required. Offered in separate bonds for soft, medium, hard, extra hard and super hard concrete. For adapter plates for other grinding machines see the Accessories page.

RECOMMENDED RPM: 550-650 for electric machines; 1800-2100 for propane machines.

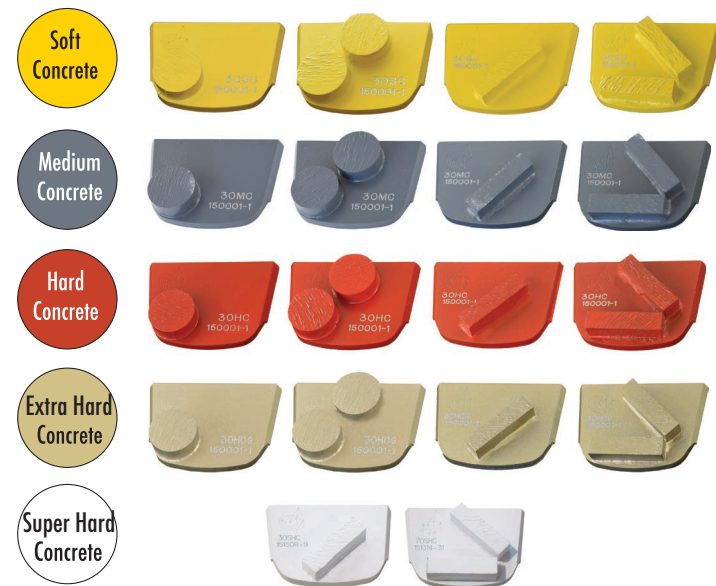

- ✓ Use the rectangular segment tools for a more aggressive cut, and for non-cementitious coating removal.
- ✓ Use the round button tools for cementitious coating removal.
- ✓ Use single segment tools with lighter machines (under 30").
- ✓ Use double segment tools with heavier machines - 30" and up.
- ✓ For a more aggressive cut, use the single rectangular segment tools during the first grinding step on all machines (tool life can vary based on the concrete hardness).



MOHS' HARDNESS PICK SET

An essential tool for determining the concrete hardness and choosing the correct metal bond tools.

Mohs' Scale	Recommended metal bond tools
2-3	● Yellow Series for Soft Concrete
3-5	● Grey Series for Medium Concrete
5-7	● Red Series for Hard Concrete
7-9	● Gold & White Series for Very Hard Concrete

CONCRETE GRINDING



Concrete with a PSI under 2500 is considered to be soft, and we recommend using our Yellow bond.



Yellow Series, One Button QC for SOFT Concrete

Item Number	Description	Tool Color	Grit
X1B-SC-0014	Quick Change single button tool for soft concrete	yellow	14
X1B-SC-0030	Quick Change single button tool for soft concrete	yellow	30
X1B-SC-0050	Quick Change single button tool for soft concrete	yellow	50
X1B-SC-0070	Quick Change single button tool for soft concrete	yellow	70
X1B-SC-0120	Quick Change single button tool for soft concrete	yellow	120

Yellow Series, Two Button QC for SOFT Concrete

Item Number	Description	Tool Color	Grit
X2B-SC-0014	Quick Change two button tool for soft concrete	yellow	14
X2B-SC-0030	Quick Change two button tool for soft concrete	yellow	30
X2B-SC-0050	Quick Change two button tool for soft concrete	yellow	50
X2B-SC-0070	Quick Change two button tool for soft concrete	yellow	70
X2B-SC-0120	Quick Change two button tool for soft concrete	yellow	120

Yellow Series, One Rectangular Segment QC for SOFT Concrete

Item Number	Description	Tool Color	Grit
X1S-SC-0014	Quick Change single segment tool for soft concrete	yellow	14
X1S-SC-0030	Quick Change single segment tool for soft concrete	yellow	30
X1S-SC-0050	Quick Change single segment tool for soft concrete	yellow	50
X1S-SC-0070	Quick Change single segment tool for soft concrete	yellow	70
X1S-SC-0120	Quick Change single segment tool for soft concrete	yellow	120

Yellow Series, Two Rectangular Segment QC for SOFT Concrete

Item Number	Description	Tool Color	Grit
X2S-SC-0014	Quick Change two segment tool for soft concrete	yellow	14
X2S-SC-0030	Quick Change two segment tool for soft concrete	yellow	30
X2S-SC-0050	Quick Change two segment tool for soft concrete	yellow	50
X2S-SC-0070	Quick Change two segment tool for soft concrete	yellow	70
X2S-SC-0120	Quick Change two segment tool for soft concrete	yellow	120

CONCRETE GRINDING

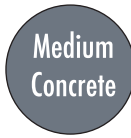

Concrete with a PSI between 2500 and 4000 is considered to be medium, and we recommend using our Gray bond.

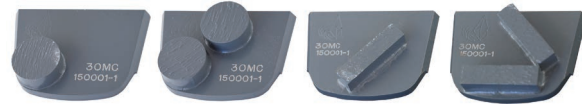

Gray Series, Single Button QC for MEDIUM Concrete

Item Number	Description	Tool Color	Grit
X1B-MC-0014	Quick Change single button tool for medium concrete	gray	14
X1B-MC-0030	Quick Change single button tool for medium concrete	gray	30
X1B-MC-0050	Quick Change single button tool for medium concrete	gray	50
X1B-MC-0070	Quick Change single button tool for medium concrete	gray	70
X1B-MC-0120	Quick Change single button tool for medium concrete	gray	120

Gray Series, Two Button QC for MEDIUM Concrete

Item Number	Description	Tool Color	Grit
X2B-MC-0014	Quick Change gray button tool for medium concrete	gray	14
X2B-MC-0030	Quick Change gray button tool for medium concrete	gray	30
X2B-MC-0050	Quick Change gray button tool for medium concrete	gray	50
X2B-MC-0070	Quick Change gray button tool for medium concrete	gray	70
X2B-MC-0120	Quick Change gray button tool for medium concrete	gray	120

Gray Series, One Rectangular Segment QC for MEDIUM Concrete

Item Number	Description	Tool Color	Grit
X1S-MC-0014	Quick Change single segment tool for medium concrete	gray	14
X1S-MC-0030	Quick Change single segment tool for medium concrete	gray	30
X1S-MC-0050	Quick Change single segment tool for medium concrete	gray	50
X1S-MC-0070	Quick Change single segment tool for medium concrete	gray	70
X1S-MC-0120	Quick Change single segment tool for medium concrete	gray	120

Gray Series, Two Rectangular Segment QC for MEDIUM Concrete

Item Number	Description	Tool Color	Grit
X2S-MC-0014	Quick Change two segment tool for medium concrete	gray	14
X2S-MC-0030	Quick Change two segment tool for medium concrete	gray	30
X2S-MC-0050	Quick Change two segment tool for medium concrete	gray	50
X2S-MC-0070	Quick Change two segment tool for medium concrete	gray	70
X2S-MC-0120	Quick Change two segment tool for medium concrete	gray	120

CONCRETE GRINDING



Concrete with a PSI between 4000 and 5500 is considered to be hard, and we recommend using our Red bond.



Red Series, One Button QC for HARD Concrete

Item Number	Description	Tool Color	Grit
X1B-HC-0030	Quick Change single button tool for hard concrete	red	30
X1B-HC-0050	Quick Change single button tool for hard concrete	red	50
X1B-HC-0070	Quick Change single button tool for hard concrete	red	70
X1B-HC-0120	Quick Change single button tool for hard concrete	red	120

Red Series, Two Button QC for HARD Concrete

Item Number	Description	Tool Color	Grit
X2B-HC-0030	Quick Change two button tool for hard concrete	red	30
X2B-HC-0050	Quick Change two button tool for hard concrete	red	50
X2B-HC-0070	Quick Change two button tool for hard concrete	red	70
X2B-HC-0120	Quick Change two button tool for hard concrete	red	120

Red Series, One Rectangular Segment QC for HARD Concrete

Item Number	Description	Tool Color	Grit
X1S-HC-0030	Quick Change single segment tool for hard concrete	red	30
X1S-HC-0050	Quick Change single segment tool for hard concrete	red	50
X1S-HC-0070	Quick Change single segment tool for hard concrete	red	70
X1S-HC-0120	Quick Change single segment tool for hard concrete	red	120

Red Series, Two Rectangular Segment QC for HARD Concrete

Item Number	Description	Tool Color	Grit
X2S-HC-0030	Quick Change two segment tool for hard concrete	red	30
X2S-HC-0050	Quick Change two segment tool for hard concrete	red	50
X2S-HC-0070	Quick Change two segment tool for hard concrete	red	70
X2S-HC-0120	Quick Change two segment tool for hard concrete	red	120

CONCRETE GRINDING



Concrete with PSI greater than 5500 is considered to be extra hard, and we recommend using our Gold bond.

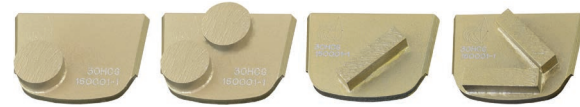

Gold Series, One Button QC for Extra Hard Concrete

Item Number	Description	Tool Color	Grit
X1B-HCG-0030	Quick Change one button tool for extra hard concrete	gold	30
X1B-HCG-0050	Quick Change one button tool for extra hard concrete	gold	50
X1B-HCG-0070	Quick Change one button tool for extra hard concrete	gold	70
X1B-HCG-0120	Quick Change one button tool for extra hard concrete	gold	120

Gold Series, Two Button QC for Extra Hard Concrete

Item Number	Description	Tool Color	Grit
X2B-HCG-0030	Quick Change two button tool for extra hard concrete	gold	30
X2B-HCG-0050	Quick Change two button tool for extra hard concrete	gold	50
X2B-HCG-0070	Quick Change two button tool for extra hard concrete	gold	70
X2B-HCG-0120	Quick Change two button tool for extra hard concrete	gold	120

Gold Series, One Rectangular Segment QC for Extra Hard Concrete

Item Number	Description	Tool Color	Grit
X1S-HCG-0030	Quick Change one segment tool for extra hard concrete	gold	30
X1S-HCG-0050	Quick Change one segment tool for extra hard concrete	gold	50
X1S-HCG-0070	Quick Change one segment tool for extra hard concrete	gold	70
X1S-HCG-0120	Quick Change one segment tool for extra hard concrete	gold	120

Gold Series, Two Rectangular Segment QC for Extra Hard Concrete

Item Number	Description	Tool Color	Grit
X2S-HCG-0030	Quick Change two segment tool for extra hard concrete	gold	30
X2S-HCG-0050	Quick Change two segment tool for extra hard concrete	gold	50
X2S-HCG-0070	Quick Change two segment tool for extra hard concrete	gold	70
X2S-HCG-0120	Quick Change two segment tool for extra hard concrete	gold	120

CONCRETE GRINDING



Concrete with PSI over 7000 is considered super hard, and we recommend using our White bond.



White Series, One Rectangular Segment QC for Super Hard Concrete

Item Number	Description	Tool Color	Grit
X1S-SHC-0030	Quick Change one segment tool for super hard concrete	white	30
X1S-SHC-0050	Quick Change one segment tool for super hard concrete	white	50
X1S-SHC-0070	Quick Change one segment tool for super hard concrete	white	70
X1S-SHC-0120	Quick Change one segment tool for super hard concrete	white	120

White Series, Two Rectangular Segment QC for Super Hard Concrete

Item Number	Description	Tool Color	Grit
X2S-SHC-0030	Quick Change two segment tool for super hard concrete	white	30
X2S-SHC-0050	Quick Change two segment tool for super hard concrete	white	50
X2S-SHC-0070	Quick Change two segment tool for super hard concrete	white	70
X2S-SHC-0120	Quick Change two segment tool for super hard concrete	white	120

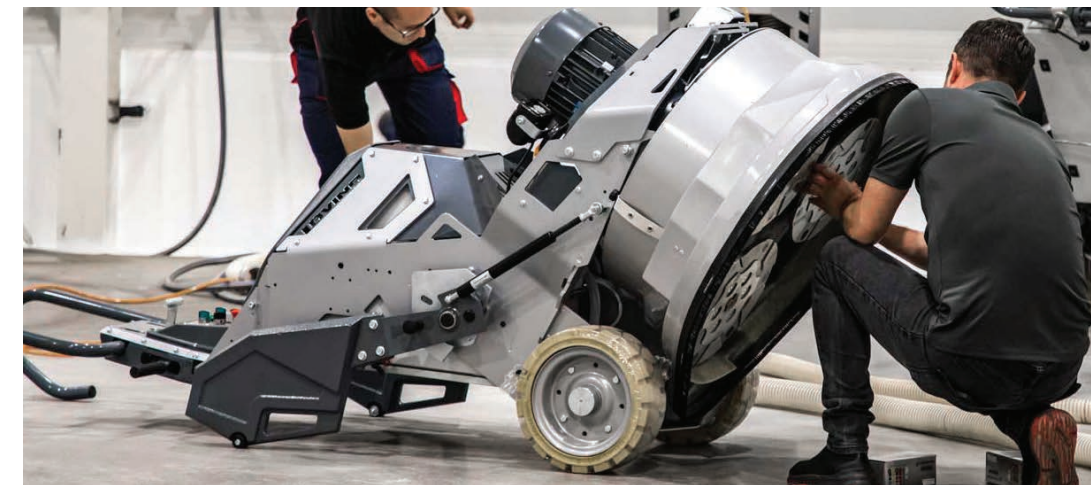

CONCRETE GRINDING

SA SUPERTHICK DISCS IN METAL BOND

Ideal for grinding concrete, natural stone, self-leveling and terrazzo floors, the SA metal discs provide a great first cut with a smooth and refined scratch pattern. Offered with velcro backing for wet applications only, and with Quick Change attachment for wet or dry use.

RECOMMENDED RPM: 650-750 for electric machines;
800-1100 for propane machines.



SA METALS, QUICK CHANGE

Item Number	Description	Size
XQC-SA-046MB	SA Superthick Metal Bond disc, Quick Change attachment, 46 Grit	3in / 80mm
XQC-SA-070MB	SA Superthick Metal Bond disc, Quick Change attachment, 70 Grit	3in / 80mm
XQC-SA-120MB	SA Superthick Metal Bond disc, Quick Change attachment, 120 Grit	3in / 80mm
XQC-SA-220MB	SA Superthick Metal Bond disc, Quick Change attachment, 220 Grit	3in / 80mm

SA METALS WITH VELCRO

Item Number	Description	Size
SA-0046MB	SA Superthick Metal Bond disc, WET, Velcro attachment, 46 Grit	3in / 80mm
SA-0070MB	SA Superthick Metal Bond disc, WET, Velcro attachment, 70 Grit	3in / 80mm
SA-0120MB	SA Superthick Metal Bond disc, WET, Velcro attachment, 120 Grit	3in / 80mm
SA-0220MB	SA Superthick Metal Bond disc, WET, Velcro attachment, 220 Grit	3in / 80mm
SA-0400MB	SA Superthick Metal Bond disc, WET, Velcro attachment, 400 Grit	3in / 80mm



Left to Right:
L20GEB with Quick Change SA Metals;
L38GREB with Calibra pucks on
Lippage Holders

TRANSITIONING, HYBRIDS

CALIBRA® CERAMIC DISCS

Calibra discs are designed for the removal of difficult scratches which are left behind by the metal bond grinding steps. These are best for hard and medium concrete applications (their life is shorter on soft or abrasive floors), and should be used **DRY**.



RECOMMENDED RPM: 650-800 for electric machines; 800-1100 for propane machines.

Item Number	Description	Size
CA3-30	CALIBRA ceramic disc, DRY, Velcro attachment, 30 Grit	3in / 76mm
CA3-50	CALIBRA ceramic disc, DRY, Velcro attachment, 50 Grit	3in / 76mm
CA3-100	CALIBRA ceramic disc, DRY, Velcro attachment, 100 Grit	3in / 76mm
CA3-200	CALIBRA ceramic disc, DRY, Velcro attachment, 200 Grit	3in / 76mm

CORSA® HYBRIDS

Ideal for scratch removal and transitioning from metals to resins and similar to Calibra discs, but the ceramic bond has been modified so that they can be used on all types of concrete. Best for **DRY** applications. Offered on foam rings or with velcro attachment.



RINGS, 9"	Description	Size
9R5COR030	CORSA Hybrid RING, DRY, Quick Change attachment, 30 Grit	9in / 228mm
9R5COR050	CORSA Hybrid RING DRY, Quick Change attachment, 50 Grit	9in / 228mm
9R5COR100	CORSA Hybrid RING, DRY, Quick Change attachment, 100 Grit	9in / 228mm
9R5COR200	CORSA Hybrid RING, DRY, Quick Change attachment, 200 Grit	9in / 228mm

RINGS, 13"	Description	Size
13R5COR030	CORSA Hybrid RING, DRY, Quick Change attachment, 30 Grit	13.2in / 335mm
13R5COR050	CORSA Hybrid RING, DRY, Quick Change attachment, 50 Grit	13.2in / 335mm
13R5COR100	CORSA Hybrid RING, DRY, Quick Change attachment, 100 Grit	13.2in / 335mm
13R5COR200	CORSA Hybrid RING, DRY, Quick Change attachment, 200 Grit	13.2in / 335mm

CORSA PUCKS, 3"	Description	Size
5COR030	CORSA Hybrid disc, DRY, Velcro attachment, 30 Grit	3in / 76mm
5COR050	CORSA Hybrid disc, DRY, Velcro attachment, 50 Grit	3in / 76mm
5COR100	CORSA Hybrid disc, DRY, Velcro attachment, 100 Grit	3in / 76mm
5COR200	CORSA Hybrid disc, DRY, Velcro attachment, 200 Grit	3in / 76mm

TRANSITIONING, HYBRIDS

HD COPPERS

The HD Coppers can be used for the first grinding steps on big box retail projects, and provide a fast cut and long tool life. For **WET** applications. Offered on foam rings or with velcro attachment.

RECOMMENDED RPM: 650-800 for electric machines; 800-1100 for propane machines.

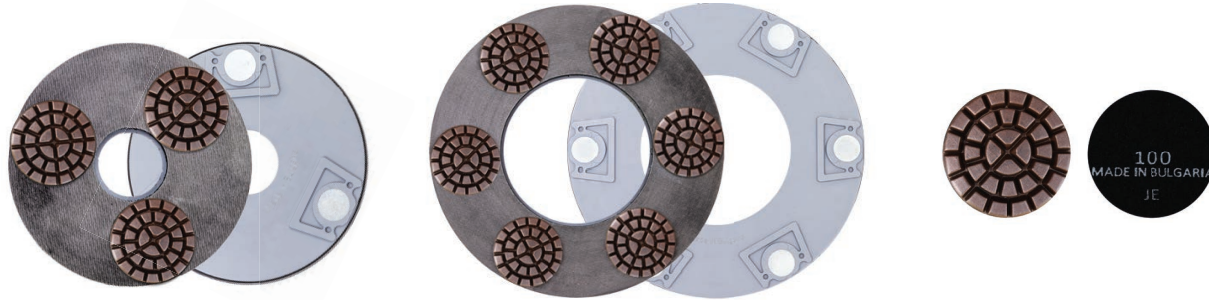

RINGS, 9"	Description	Size
R9HDCO50	HD COPPER RING, WET, Quick Change attachment, 50 Grit	9in / 228mm
R9HDCO100	HD COPPER RING, WET, Quick Change attachment, 100 Grit	9in / 228mm
R9HDCO200	HD COPPER RING, WET, Quick Change attachment, 200 Grit	9in / 228mm
R9HDCO400	HD COPPER RING, WET, Quick Change attachment, 400 Grit	9in / 228mm

RINGS, 13"	Description	Size
R13HDCO50	HD COPPER RING, WET, Quick Change attachment, 50 Grit	13.2in / 335mm
R13HDCO100	HD COPPER RING, WET, Quick Change attachment, 100 Grit	13.2in / 335mm
R13HDCO200	HD COPPER RING, WET, Quick Change attachment, 200 Grit	13.2in / 335mm
R13HDCO400	HD COPPER RING, WET, Quick Change attachment, 400 Grit	13.2in / 335mm

COPPER PUCKS, 3"	Description	Size
HD-3-CO-0050-R	HD COPPER disc, WET, Velcro attachment, 50 Grit	3in / 76mm
HD-3-CO-0100-R	HD COPPER disc, WET, Velcro attachment, 100 Grit	3in / 76mm
HD-3-CO-0200-R	HD COPPER disc, WET, Velcro attachment, 200 Grit	3in / 76mm
HD-3-CO-0400-R	HD COPPER disc, WET, Velcro attachment, 400 Grit	3in / 76mm

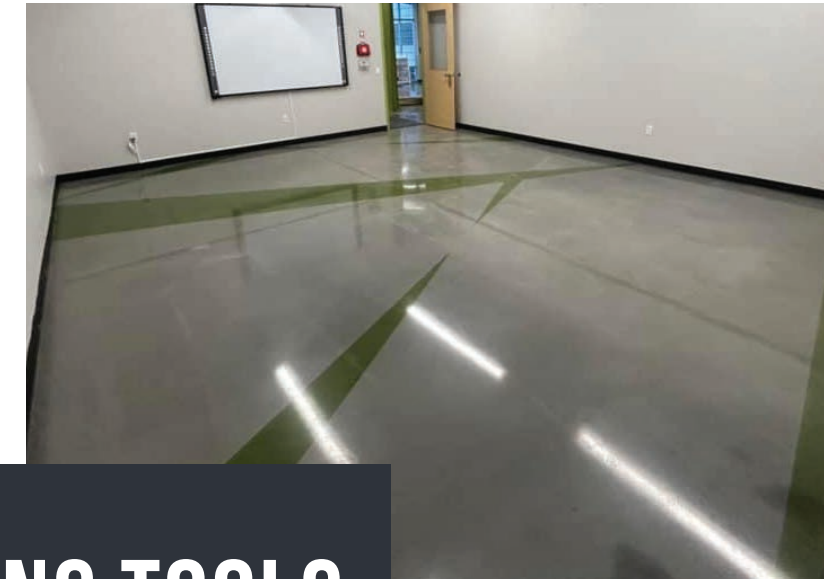
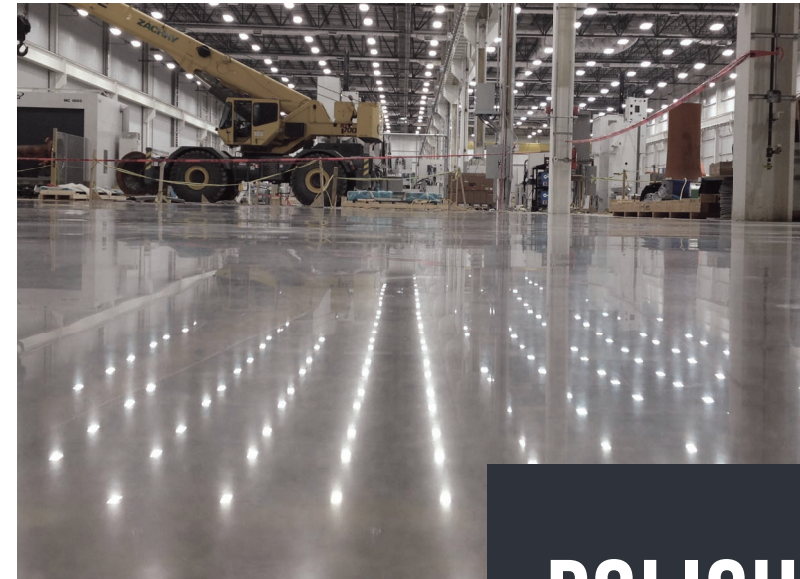

POLISHING TOOLS

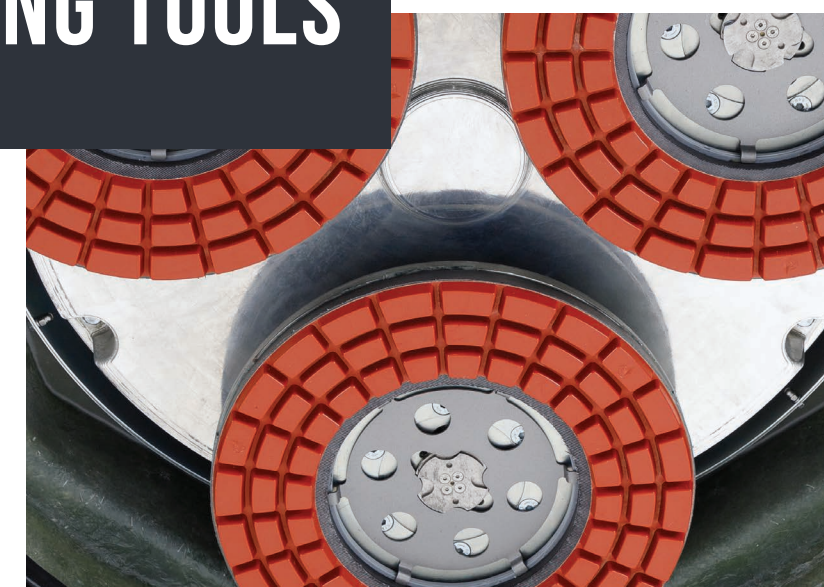

CONCRETE POLISHING

NATO® POLISHING DISCS

NATO discs feature a thick 12mm layer of resin and diamonds for extra long life. Wide channels and a unique patented design allow for work on a cleaner surface, ensuring a quality polish. Offered in separate dry and wet resin bond on foam rings or with velcro attachment.

RECOMMENDED RPM: up to 120 grit - 650-750 rpm on electric machines; 200 grit and up - 800-1100 rpm on electric machines; 800-1100 rpm on propane machines.

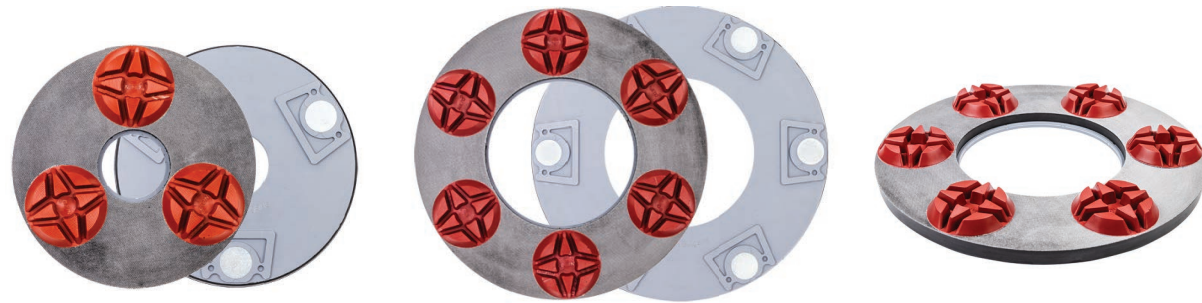

NATO RINGS, 9"

DRY BOND	WET BOND	<u>Description</u>	<u>Size</u>
R9NS0050D	R9NS0050	NATO Polishing RING, Quick Change Attachment	9in / 228mm
R9NS0100D	R9NS0120	NATO Polishing RING, Quick Change Attachment	9in / 228mm
R9NS0200D	R9NS0220	NATO Polishing RING, Quick Change Attachment	9in / 228mm
R9NS0400D	R9NS0400	NATO Polishing RING, Quick Change Attachment	9in / 228mm
R9NS0800D	R9NS0800	NATO Polishing RING, Quick Change Attachment	9in / 228mm
R9NS1500D	R9NS1800	NATO Polishing RING, Quick Change Attachment	9in / 228mm

NATO RINGS, 13"

DRY BOND	WET BOND	<u>Description</u>	<u>Size</u>
R13NS0050	R13NS0050	NATO Polishing RING, Quick Change Attachment	13.2in / 335mm
R13NS0120	R13NS0120	NATO Polishing RING, Quick Change Attachment	13.2in / 335mm
R13NS0220	R13NS0220	NATO Polishing RING, Quick Change Attachment	13.2in / 335mm
R13NS0400	R13NS0400	NATO Polishing RING, Quick Change Attachment	13.2in / 335mm
R13NS0800	R13NS0800	NATO Polishing RING, Quick Change Attachment	13.2in / 335mm
R13NS1800	R13NS1800	NATO Polishing RING, Quick Change Attachment	13.2in / 335mm

CONCRETE POLISHING

NATO PUCKS WITH VELCRO, 3"

Also offered in 4" size.



DRY BOND	WET BOND	<u>Description</u>	<u>Size</u>
NS-0030D	NS-0030	NATO Polishing Disc, Velcro Attachment	3in / 81.5mm
NS-0050D	NS-0050	NATO Polishing Disc, Velcro Attachment	3in / 81.5mm
NS-0100D	NS-0120	NATO Polishing Disc, Velcro Attachment	3in / 81.5mm
NS-0200D	NS-0220	NATO Polishing Disc, Velcro Attachment	3in / 81.5mm
NS-0400D	NS-0400	NATO Polishing Disc, Velcro Attachment	3in / 81.5mm
NS-0800D	NS-0800	NATO Polishing Disc, Velcro Attachment	3in / 81.5mm
NS-1500D	NS-1800	NATO Polishing Disc, Velcro Attachment	3in / 81.5mm
NS-3000D	NS-3500	NATO Polishing Disc, Velcro Attachment	3in / 81.5mm



V-HARR® PREMIUM POLISHING PADS

V-HARR featuring a combination of premium felt and resin drops, is one of Superabrasive’s most versatile and popular polishing tools, designed for mechanically restoring and polishing concrete. **Dry use is strongly recommended for concrete applications.** V-HARR is also ideal for terrazzo and hard stone floors, and will produce remarkable gloss results on black granite when used wet.

RECOMMENDED RPM: 800-1100 rpm.

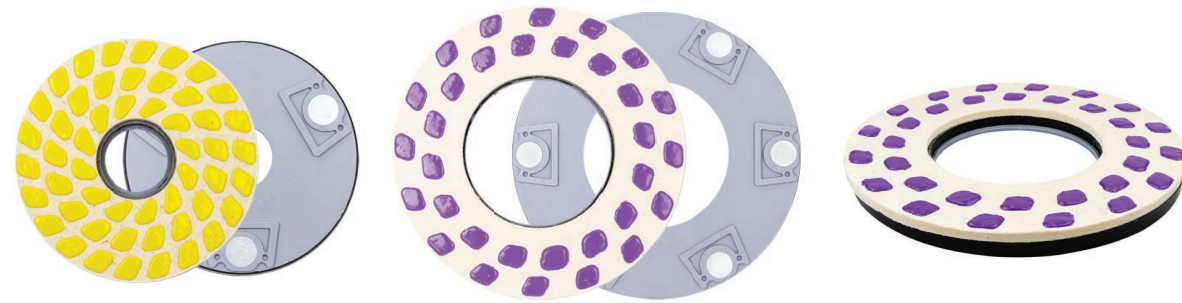

RINGS 9”	Description	Size
R9VF0050	V-HARR® Polishing RING, Dry, Quick Change, 50 Grit	9in / 228mm
R9VF0120	V-HARR® Polishing RING, Dry, Quick Change, 120 Grit	9in / 228mm
R9VF0220	V-HARR® Polishing RING, Dry, Quick Change, 220 Grit	9in / 228mm
R9VF0400	V-HARR® Polishing RING, Dry, Quick Change, 400 Grit	9in / 228mm
R9VF0800	V-HARR® Polishing RING, Dry, Quick Change, 800 Grit	9in / 228mm
R9VF1800	V-HARR® Polishing RING, Dry, Quick Change, 1800 Grit	9in / 228mm
R9VF3500	V-HARR® Polishing RING, Dry, Quick Change, 3500 Grit	9in / 228mm
R9VFBUFF	V-HARR® Polishing RING, Dry, Quick Change, 8500 Grit	9in / 228mm

RINGS 13”	Description	Size
R13VF0050	V-HARR® Polishing RING, Dry, Quick Change, 50 Grit	13.2in / 335mm
R13VF0120	V-HARR® Polishing RING, Dry, Quick Change, 120 Grit	13.2in / 335mm
R13VF0220	V-HARR® Polishing RING, Dry, Quick Change, 220 Grit	13.2in / 335mm
R13VF0400	V-HARR® Polishing RING, Dry, Quick Change, 400 Grit	13.2in / 335mm
R13VF0800	V-HARR® Polishing RING, Dry, Quick Change, 800 Grit	13.2in / 335mm
R13VF1800	V-HARR® Polishing RING, Dry, Quick Change, 1800 Grit	13.2in / 335mm
R13VF3500	V-HARR® Polishing RING, Dry, Quick Change, 3500 Grit	13.2in / 335mm
R13VFBUFF	V-HARR® Polishing RING, Dry, Quick Change, 8500 Grit	13.2in / 335mm

The velcro style V-HARR pads are offered in many popular sizes (5”, 7”, 9”, 10.63”, 13”, etc).

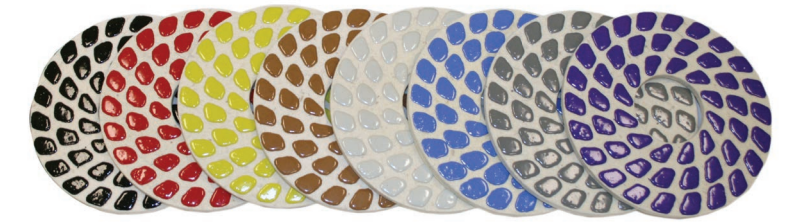

V-HARR PADS WITH VELCRO, 9”

Item Number	Description	Size
VF-9-0120	V-HARR® Polishing Pad, Dry, Velcro Attachment, 120 Grit	9in / 225mm
VF-9-0220	V-HARR® Polishing Pad, Dry, Velcro Attachment, 220 Grit	9in / 225mm
VF-9-0400	V-HARR® Polishing Pad, Dry, Velcro Attachment, 400 Grit	9in / 225mm
VF-9-0800	V-HARR® Polishing Pad, Dry, Velcro Attachment, 800 Grit	9in / 225mm
VF-9-1800	V-HARR® Polishing Pad, Dry, Velcro Attachment, 1800 Grit	9in / 225mm
VF-9-3500	V-HARR® Polishing Pad, Dry, Velcro Attachment, 3500 Grit	9in / 225mm
VF-9-BUFF	V-HARR® Polishing Pad, Dry, Velcro Attachment, 8500 Grit	9in / 225mm

V-HARR PADS WITH VELCRO, 10.63”

Item Number	Description	Size
VF-10.63-0120	V-HARR® Polishing Pad, Dry, Velcro Attachment, 120 Grit	10.63in / 270mm
VF-10.63-0220	V-HARR® Polishing Pad, Dry, Velcro Attachment, 220 Grit	10.63in / 270mm
VF-10.63-0400	V-HARR® Polishing Pad, Dry, Velcro Attachment, 400 Grit	10.63in / 270mm
VF-10.63-0800	V-HARR® Polishing Pad, Dry, Velcro Attachment, 800 Grit	10.63in / 270mm
VF-10.63-1800	V-HARR® Polishing Pad, Dry, Velcro Attachment, 1800 Grit	10.63in / 270mm
VF-10.63-3500	V-HARR® Polishing Pad, Dry, Velcro Attachment, 3500 Grit	10.63in / 270mm
VF-10.63-BUFF	V-HARR® Polishing Pad, Dry, Velcro Attachment, 8500 Grit	10.63in / 270mm

V-HARR PADS WITH VELCRO, 13”

Item Number	Description	Size
VF-13.5-0220	V-HARR® Polishing Pad, Dry, Velcro Attachment, 220 Grit	13.2in / 335mm
VF-13.5-0400	V-HARR® Polishing Pad, Dry, Velcro Attachment, 400 Grit	13.2in / 335mm
VF-13.5-0800	V-HARR® Polishing Pad, Dry, Velcro Attachment, 800 Grit	13.2in / 335mm
VF-13.5-1800	V-HARR® Polishing Pad, Dry, Velcro Attachment, 1800 Grit	13.2in / 335mm
VF-13.5-3500	V-HARR® Polishing Pad, Dry, Velcro Attachment, 3500 Grit	13.2in / 335mm
VF-13.5-BUFF	V-HARR® Polishing Pad, Dry, Velcro Attachment, 8500 Grit	13.2in / 335mm

WAFFEL POLISHING PADS

WAFFEL polishing pads are offered in separate wet and dry resin bond on foam rings or with a standard velcro attachment.

RECOMMENDED RPM: up to 120 grit - 650-750 rpm on electric machines; 200 grit and up - 800-1100 rpm on electric machines; 800-1100 rpm on propane machines.

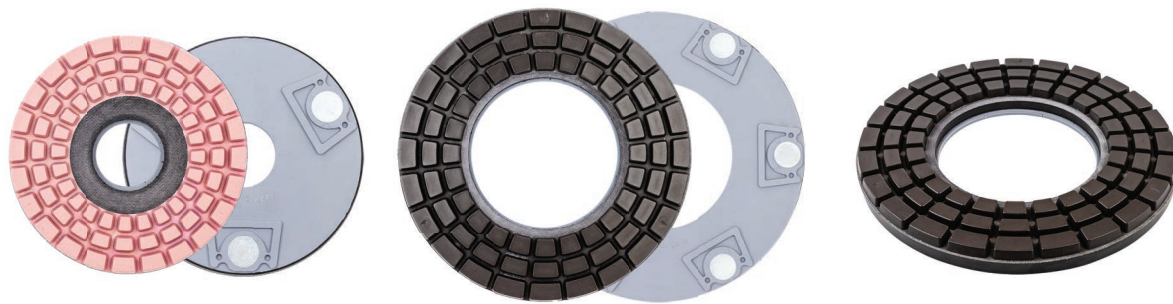

WAFFEL RINGS, 9"

DRY BOND	WET BOND	Description	Size
R9WF0050D	R9WF0050	WAFFEL RING, Quick Change Attachment	9in / 228mm
R9WF0100D	R9WF0120	WAFFEL RING, Quick Change Attachment	9in / 228mm
R9WF0200D	R9WF0220	WAFFEL RING, Quick Change Attachment	9in / 228mm
R9WF0400D	R9WF0400	WAFFEL RING, Quick Change Attachment	9in / 228mm
R9WF0800D	R9WF0800	WAFFEL RING, Quick Change Attachment	9in / 228mm
R9WF1500D	R9WF1800	WAFFEL RING, Quick Change Attachment	9in / 228mm

WAFFEL RINGS, 13"

DRY BOND	WET BOND	Description	Size
R13WF0050D	R13WF0050	WAFFEL RING, Quick Change Attachment	13.2in / 335mm
R13WF0100D	R13WF0120	WAFFEL RING, Quick Change Attachment	13.2in / 335mm
R13WF0200D	R13WF0220	WAFFEL RING, Quick Change Attachment	13.2in / 335mm
R13WF0400D	R13WF0400	WAFFEL RING, Quick Change Attachment	13.2in / 335mm
R13WF0800D	R13WF0800	WAFFEL RING, Quick Change Attachment	13.2in / 335mm
R13WF1500D	R13WF1800	WAFFEL RING, Quick Change Attachment	13.2in / 335mm

Waffel, Dry Bond



WAFFEL PADS WITH VELCRO, 9"

DRY BOND	WET BOND	Description	Size
WAFF-9-0050D	WAFF-9-0050	WAFFEL Floor Polishing Pad, Velcro Attachment	9in / 228mm
WAFF-9-0100D	WAFF-9-0120	WAFFEL Floor Polishing Pad, Velcro Attachment	9in / 228mm
WAFF-9-0200D	WAFF-9-0220	WAFFEL Floor Polishing Pad, Velcro Attachment	9in / 228mm
WAFF-9-0400D	WAFF-9-0400	WAFFEL Floor Polishing Pad, Velcro Attachment	9in / 228mm
WAFF-9-0800D	WAFF-9-0800	WAFFEL Floor Polishing Pad, Velcro Attachment	9in / 228mm
WAFF-9-1500D	WAFF-9-1800	WAFFEL Floor Polishing Pad, Velcro Attachment	9in / 228mm

WAFFEL PADS WITH VELCRO, 10.63"

DRY BOND	WET BOND	Description	Size
WAFF-10.63-0050D	WAFF-10.63-0050	WAFFEL Floor Polishing Pad, Velcro Attachment	10.63in / 270mm
WAFF-10.63-0100D	WAFF-10.63-0120	WAFFEL Floor Polishing Pad, Velcro Attachment	10.63in / 270mm
WAFF-10.63-0200D	WAFF-10.63-0220	WAFFEL Floor Polishing Pad, Velcro Attachment	10.63in / 270mm
WAFF-10.63-0400D	WAFF-10.63-0400	WAFFEL Floor Polishing Pad, Velcro Attachment	10.63in / 270mm
WAFF-10.63-0800D	WAFF-10.63-0800	WAFFEL Floor Polishing Pad, Velcro Attachment	10.63in / 270mm
WAFF-10.63-1500D	WAFF-10.63-1800	WAFFEL Floor Polishing Pad, Velcro Attachment	10.63in / 270mm

Waffel, Wet Bond



3-STEP SYSTEM, DRY

Quick and simple concrete polishing system delivers premium shine. Featuring a new proprietary resin bond formula, and suitable for any type of concrete. For best results, use them DRY. The floor should be cut to 120 grit with a metal or hybrid diamond tool, and densified, if necessary, before starting with Step 1.

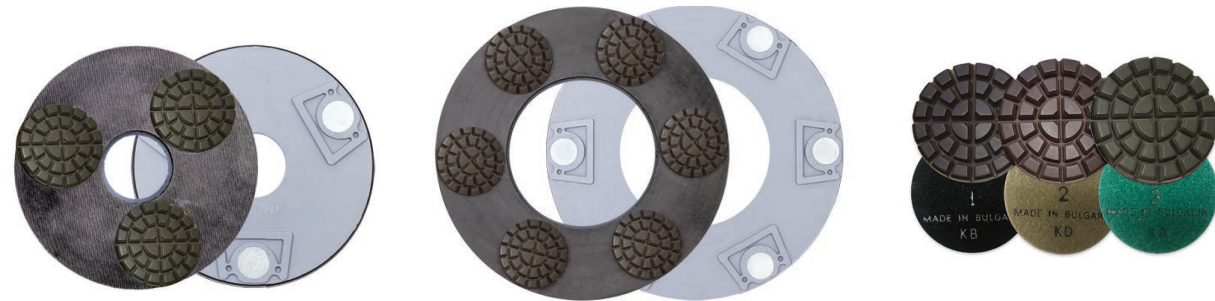

RINGS, 9"	Description	Size
R93S1	3-STEP Floor Polishing RING, Quick Change Attachment, Step 1	9in / 228mm
R93S2	3-STEP Floor Polishing RING, Quick Change Attachment, Step 2	9in / 228mm
R93S3	3-STEP Floor Polishing RING, Quick Change Attachment, Step 3	9in / 228mm

RINGS, 13"	Description	Size
R133S1	3-STEP Floor Polishing RING, Quick Change Attachment, Step 1	13.2in / 335mm
R133S2	3-STEP Floor Polishing RING, Quick Change Attachment, Step 2	13.2in / 335mm
R133S3	3-STEP Floor Polishing RING, Quick Change Attachment, Step 3	13.2in / 335mm

3-STEP PUCKS, 3"	Description	Size
3S-1	3-STEP Floor Polishing Pad, Velcro Attachment, Step 1	3in / 77mm
3S-2	3-STEP Floor Polishing Pad, Velcro Attachment, Step 2	3in / 77mm
3S-3	3-STEP Floor Polishing Pad, Velcro Attachment, Step 3	3in / 77mm



HD RESIN PADS

A popular polishing pad made with high quality diamond-resin bond that can be used dry or wet. Works best with heavier grinders (30-inch and up). Make sure you add weights if you are using them on lighter machines. Available on foam rings or with velcro attachment (3" and 4" size).

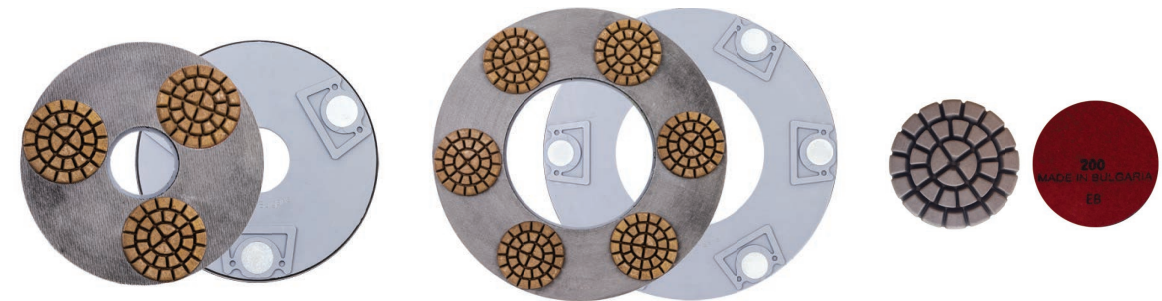

RINGS, 9"	Description	Size
R9HD0030	HD Resin RING, Quick Change Attachment, 30 Grit	9in / 228mm
R9HD0050	HD Resin RING, Quick Change Attachment, 50 Grit	9in / 228mm
R9HD0100	HD Resin RING, Quick Change Attachment, 100 Grit	9in / 228mm
R9HD0200	HD Resin RING, Quick Change Attachment, 200 Grit	9in / 228mm
R9HD0400	HD Resin RING, Quick Change Attachment, 400 Grit	9in / 228mm
R9HD0800	HD Resin RING, Quick Change Attachment, 800 Grit	9in / 228mm
R9HD1500	HD Resin RING, Quick Change Attachment, 1500 Grit	9in / 228mm
R9HD3000	HD Resin RING, Quick Change Attachment, 3000 Grit	9in / 228mm

RINGS, 13"	Description	Size
R13HD0030	HD Resin RING, Quick Change Attachment, 30 Grit	13.2in / 335mm
R13HD0050	HD Resin RING, Quick Change Attachment, 50 Grit	13.2in / 335mm
R13HD0100	HD Resin RING, Quick Change Attachment, 100 Grit	13.2in / 335mm
R13HD0200	HD Resin RING, Quick Change Attachment, 200 Grit	13.2in / 335mm
R13HD0400	HD Resin RING, Quick Change Attachment, 400 Grit	13.2in / 335mm
R13HD0800	HD Resin RING, Quick Change Attachment, 800 Grit	13.2in / 335mm
R13HD1500	HD Resin RING, Quick Change Attachment, 1500 Grit	13.2in / 335mm
R13HD3000	HD Resin RING, Quick Change Attachment, 3000 Grit	13.2in / 335mm

HD PUCKS, 3"	Description	Size
HD-3-0030	HD Resin Disc, Velcro Attachment, 30 Grit	3in / 77mm
HD-3-0050	HD Resin Disc, Velcro Attachment, 50 Grit	3in / 77mm
HD-3-0100	HD Resin Disc, Velcro Attachment, 100 Grit	3in / 77mm
HD-3-0200	HD Resin Disc, Velcro Attachment, 200 Grit	3in / 77mm
HD-3-0400	HD Resin Disc, Velcro Attachment, 400 Grit	3in / 77mm
HD-3-0800	HD Resin Disc, Velcro Attachment, 800 Grit	3in / 77mm
HD-3-1500	HD Resin Disc, Velcro Attachment, 1500 Grit	3in / 77mm
HD-3-3000	HD Resin Disc, Velcro Attachment, 3000 Grit	3in / 77mm

STONE GRINDING AND POLISHING

FLEXIBLE ELECTROPLATED PADS

Designed for fine grinding and honing of natural stone, engineered stone, and fine wood surfaces, but they work best on softer natural stones such as marble, travertine, limestone, and onyx.

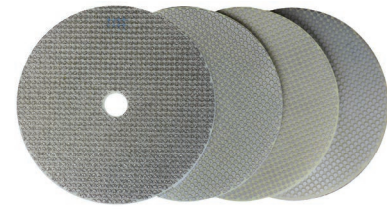

Available in a variety of sizes - 3, 4, 5, 7 and 9-inches.

Item Number	Description	Size
3EL-FL-0050	Flexible electroplated pad, 3 inch, 50 grit	3in / 76mm
3EL-FL-0070	Flexible electroplated pad, 3 inch, 70 grit	3in / 76mm
3EL-FL-0120	Flexible electroplated pad, 3 inch, 120 grit	3in / 76mm
3EL-FL-0220	Flexible electroplated pad, 3 inch, 220 grit	3in / 76mm
3EL-FL-0400	Flexible electroplated pad, 3 inch, 400 grit	3in / 76mm
3EL-FL-0600	Flexible electroplated pad, 3 inch, 600 grit	3in / 76mm
4EL-FL-0050	Flexible electroplated pad, 4 inch, 50 grit	4in / 102mm
4EL-FL-0070	Flexible electroplated pad, 4 inch, 70 grit	4in / 102mm
4EL-FL-0120	Flexible electroplated pad, 4 inch, 120 grit	4in / 102mm
4EL-FL-0220	Flexible electroplated pad, 4 inch, 220 grit	4in / 102mm
4EL-FL-0400	Flexible electroplated pad, 4 inch, 400 grit	4in / 102mm
4EL-FL-0600	Flexible electroplated pad, 4 inch, 600 grit	4in / 102mm
5EL-FL-0050	Flexible electroplated pad, 5 inch, 50 grit	5in / 127mm
5EL-FL-0070	Flexible electroplated pad, 5 inch, 70 grit	5in / 127mm
5EL-FL-0120	Flexible electroplated pad, 5 inch, 120 grit	5in / 127mm
5EL-FL-0220	Flexible electroplated pad, 5 inch, 220 grit	5in / 127mm
5EL-FL-0400	Flexible electroplated pad, 5 inch, 400 grit	5in / 127mm
5EL-FL-0600	Flexible electroplated pad, 5 inch, 600 grit	5in / 127mm
7EL-FL-0050	Flexible electroplated pad, 7 inch, 50 grit	7in / 178mm
7EL-FL-0070	Flexible electroplated pad, 7 inch, 70 grit	7in / 178mm
7EL-FL-0120	Flexible electroplated pad, 7 inch, 120 grit	7in / 178mm
7EL-FL-0220	Flexible electroplated pad, 7 inch, 220 grit	7in / 178mm
7EL-FL-0400	Flexible electroplated pad, 7 inch, 400 grit	7in / 178mm
7EL-FL-0600	Flexible electroplated pad, 7 inch, 600 grit	7in / 178mm

STONE GRINDING AND POLISHING

SPIRAL POLISHING PADS

The undisputed solution for polishing natural stone floors. 3-inch resin pads with velcro attachment, offered in two spiral patterns, which allow water to efficiently dispose of slurry, keeping the working surface clean.

**SPIRAL Pads
for medium to soft stones
(marble, travertine, onyx,
and limestone)**



Item Number	Description	Size
10-3-0030	Spiral Pad for Stone, Velcro Attachment, WET, 30 Grit	3in / 76mm
10-3-0050	Spiral Pad for Stone, Velcro Attachment, WET, 50 Grit	3in / 76mm
10-3-0120	Spiral Pad for Stone, Velcro Attachment, WET, 120 Grit	3in / 76mm
10-3-0220	Spiral Pad for Stone, Velcro Attachment, WET, 220 Grit	3in / 76mm
10-3-0400	Spiral Pad for Stone, Velcro Attachment, WET, 400 Grit	3in / 76mm
10-3-0800	Spiral Pad for Stone, Velcro Attachment, WET, 800 Grit	3in / 76mm
10-3-1800	Spiral Pad for Stone, Velcro Attachment, WET, 1800 Grit	3in / 76mm
10-3-3500	Spiral Pad for Stone, Velcro Attachment, WET, 3500 Grit	3in / 76mm
10-3-8500	Spiral Pad for Stone, Velcro Attachment, WET, 8500 Grit	3in / 76mm

**SPIRAL Pads
with wide channels
for harder stones,
such as granite**



Item Number	Description	Size
10-SA-0050	Spiral Pad for Stone, Wide Channels, Velcro Attachment, WET, 50 Grit	3in / 76mm
10-SA-0120	Spiral Pad for Stone, Wide Channels, Velcro Attachment, WET, 120 Grit	3in / 76mm
10-SA-0220	Spiral Pad for Stone, Wide Channels, Velcro Attachment, WET, 220 Grit	3in / 76mm
10-SA-0400	Spiral Pad for Stone, Wide Channels, Velcro Attachment, WET, 400 Grit	3in / 76mm
10-SA-0800	Spiral Pad for Stone, Wide Channels, Velcro Attachment, WET, 800 Grit	3in / 76mm
10-SA-1800	Spiral Pad for Stone, Wide Channels, Velcro Attachment, WET, 1800 Grit	3in / 76mm
10-SA-3500	Spiral Pad for Stone, Wide Channels, Velcro Attachment, WET, 3500 Grit	3in / 76mm
10-SA-8500	Spiral Pad for Stone, Wide Channels, Velcro Attachment, WET, 8500 Grit	3in / 76mm

CORNERS AND EDGES

EDGE MASTER



EDGE MASTER TURBO CUPS

5-inch and 7-inch turbo cups featuring our high performing ceramic bond, offered in different grit sizes to refine and blend your edge work faster and more efficiently. Use the Extra Coarse step only when you need to remove deep scratches and gouges, or any hard topical materials on the edges. Suitable for wet and dry use, on all types of concrete.

Offered with 5/8-11 or M14 threaded attachment, and can be used with most handheld grinders.

Item Number	Description	Size
EM-5-XC	Edge Master Ceramic Turbo Cup, 5/8-11, Extra Coarse	5in / 125mm
EM-5-C	Edge Master Ceramic Turbo Cup, 5/8-11, Coarse	5in / 125mm
EM-5-M	Edge Master Ceramic Turbo Cup, 5/8-11, Medium	5in / 125mm
EM-5-F	Edge Master Ceramic Turbo Cup, 5/8-11, Fine	5in / 125mm
EM-5-XF	Edge Master Ceramic Turbo Cup, 5/8-11, Extra Fine	5in / 125mm

Item Number	Description	Size
EM-7-XC	Edge Master Ceramic Turbo Cup, 5/8-11, Extra Coarse	7in / 178mm
EM-7-C	Edge Master Ceramic Turbo Cup, 5/8-11, Coarse	7in / 178mm
EM-7-M	Edge Master Ceramic Turbo Cup, 5/8-11, Medium	7in / 178mm
EM-7-F	Edge Master Ceramic Turbo Cup, 5/8-11, Fine	7in / 178mm
EM-7-XF	Edge Master Ceramic Turbo Cup, 5/8-11, Extra Fine	7in / 178mm

METAL AND COPPER RINGS FOR STONE

These rings are an aggressive solution for removing stock and deep scratches in stone surfaces, including granite, marble, travertine, and others. We do not recommend them for work on concrete or engineered stone. For **WET use** only! Offered in 3 and 4 Inch.



Item Number	Description	Size
SAMBR3-46	Metal bond ring for stone grinding, 3 inch, 46 grit	3in / 76mm
SAMBR3-70	Metal bond ring for stone grinding, 3 inch, 70 grit	3in / 76mm
SARBR3-120	Copper bond ring for stone grinding, 3 inch, 120 grit	3in / 76mm

CORNERS AND EDGES

3N COPPER PADS

An excellent solution for corner grinding and honing. Offered in 4 and 5 inch sizes for use with any hand-held grinder.

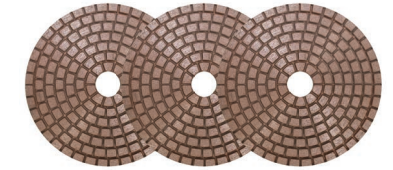

Item Number	Description	Size
3N-4-CO030	3N Copper Pad for Polishing, 4 Inch, 30 Grit	4in / 101.6mm
3N-4-CO050	3N Copper Pad for Polishing, 4 Inch, 50 Grit	4in / 101.6mm
3N-4-CO070	3N Copper Pad for Polishing, 4 Inch, 70 Grit	4in / 101.6mm
3N-4-CO120	3N Copper Pad for Polishing, 4 Inch, 120 Grit	4in / 101.6mm
3N-4-CO220	3N Copper Pad for Polishing, 4 Inch, 220 Grit	4in / 101.6mm

Item Number	Description	Size
3N-5-CO030	3N Copper Pad for Polishing, 5 Inch, 30 Grit	5in / 125mm
3N-5-CO050	3N Copper Pad for Polishing, 5 Inch, 50 Grit	5in / 125mm
3N-5-CO070	3N Copper Pad for Polishing, 5 Inch, 70 Grit	5in / 125mm
3N-5-CO120	3N Copper Pad for Polishing, 5 Inch, 120 Grit	5in / 125mm
3N-5-CO220	3N Copper Pad for Polishing, 5 Inch, 220 Grit	5in / 125mm

CORNERPRO SYSTEM

CornerPro pads feature a special triangular shape for reaching the furthest depths of corners and edges. Offered in brazed, resin, and electroplated bonds to accommodate various applications.

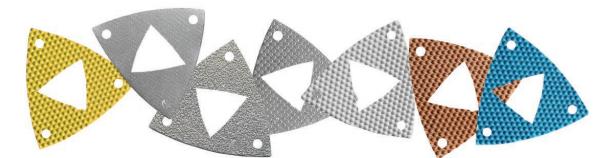

Item Number	Description	Size
3ANG-BR-0046	Triangle-shaped CornerPro tool, brazed bond, 46 grit	standard
3ANG-EL-0050	Triangle-shaped CornerPro tool, electroplated bond, 50 grit	standard
3ANG-EL-0120	Triangle-shaped CornerPro tool, electroplated bond, 120 grit	standard
3ANG-EL-0220	Triangle-shaped CornerPro tool, electroplated bond, 220 grit	standard
3ANG-EL-0400	Triangle-shaped CornerPro tool, electroplated bond, 400 grit	standard
3ANG-EL-0600	Triangle-shaped CornerPro tool, electroplated bond, 600 grit	standard
3ANG-ES-0400	Triangle-shaped CornerPro tool, resin bond, 400 grit	standard
3ANG-ES-0600	Triangle-shaped CornerPro tool, resin bond, 600 grit	standard
3ANG-ES-0800	Triangle-shaped CornerPro tool, resin bond, 800 grit	standard
3ANG-ES-1800	Triangle-shaped CornerPro tool, resin bond, 1800 grit	standard

STONE COUNTERTOPS

3N RESIN POLISHING PADS FOR NATURAL STONE

The 3N pads are a flexible and durable solution for polishing marble and granite. Available in a wide variety of sizes including 3, 4, 5, and 7 inches.

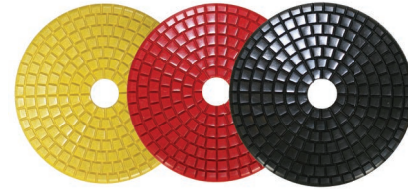

3N RESIN POLISHING PADS, 4"

Item Number	Description	Size
3N-4-0050	3N Polishing Pads, 4 Inch, Resin, 50 Grit	4 inch / 101.6 mm
3N-4-0120	3N Polishing Pads, 4 Inch, Resin, 120 Grit	4 inch / 101.6 mm
3N-4-0220	3N Polishing Pads, 4 Inch, Resin, 220 Grit	4 inch / 101.6 mm
3N-4-0400	3N Polishing Pads, 4 Inch, Resin, 400 Grit	4 inch / 101.6 mm
3N-4-0800	3N Polishing Pads, 4 Inch, Resin, 800 Grit	4 inch / 101.6 mm
3N-4-1800	3N Polishing Pads, 4 Inch, Resin, 1800 Grit	4 inch / 101.6 mm
3N-4-3500	3N Polishing Pads, 4 Inch, Resin, 3500 Grit	4 inch / 101.6 mm
3N-4-8500	3N Polishing Pads, 4 Inch, Resin, 8500 Grit	4 inch / 101.6 mm

3N RESIN POLISHING PADS, 5"

Item Number	Description	Size
3N-5-0050	3N Polishing Pads, 5 Inch, Resin, 50 Grit	5 inch / 125 mm
3N-5-0120	3N Polishing Pads, 5 Inch, Resin, 120 Grit	5 inch / 125 mm
3N-5-0220	3N Polishing Pads, 5 Inch, Resin, 220 Grit	5 inch / 125 mm
3N-5-0400	3N Polishing Pads, 5 Inch, Resin, 400 Grit	5 inch / 125 mm
3N-5-0800	3N Polishing Pads, 5 Inch, Resin, 800 Grit	5 inch / 125 mm
3N-5-1800	3N Polishing Pads, 5 Inch, Resin, 1800 Grit	5 inch / 125 mm
3N-5-3500	3N Polishing Pads, 5 Inch, Resin, 3500 Grit	5 inch / 125 mm
3N-5-8500	3N Polishing Pads, 5 Inch, Resin, 8500 Grit	5 inch / 125 mm

CONCRETE COUNTERTOPS

3N HIGH PERFORMANCE POLISHING PADS

The go-to solution for concrete countertop professionals. Featuring a dry-only High Performance bond, these pads achieve an exceptionally smooth and even polish on concrete countertops. Available in 4 and 5 inch sizes.



3N HIGH PERFORMANCE PADS, DRY, 4"

Item Number	Description	Size
3N-HP-4-0050	3N High Performance Pads, 4 Inch, Resin, Dry Only, 50 Grit	4in / 101.6mm
3N-HP-4-0100	3N High Performance Pads, 4 Inch, Resin, Dry Only, 100 Grit	4in / 101.6mm
3N-HP-4-0200	3N High Performance Pads, 4 Inch, Resin, Dry Only, 200 Grit	4in / 101.6mm
3N-HP-4-0400	3N High Performance Pads, 4 Inch, Resin, Dry Only, 400 Grit	4in / 101.6mm
3N-HP-4-0800	3N High Performance Pads, 4 Inch, Resin, Dry Only, 800 Grit	4in / 101.6mm
3N-HP-4-1500	3N High Performance Pads, 4 Inch, Resin, Dry Only, 1500 Grit	4in / 101.6mm
3N-HP-4-3000	3N High Performance Pads, 4 Inch, Resin, Dry Only, 3000 Grit	4in / 101.6mm
3N-HP-4-BUFF	3N High Performance Pads, 4 Inch, Resin, Dry Only, BUFF Grit	4in / 101.6mm

3N HIGH PERFORMANCE PADS, DRY, 5"

Item Number	Description	Size
3N-HP-5-0050	3N High Performance Pads, 5 Inch, Resin, Dry Only, 50 Grit	5in / 125mm
3N-HP-5-0100	3N High Performance Pads, 5 Inch, Resin, Dry Only, 100 Grit	5in / 125mm
3N-HP-5-0200	3N High Performance Pads, 5 Inch, Resin, Dry Only, 200 Grit	5in / 125mm
3N-HP-5-0400	3N High Performance Pads, 5 Inch, Resin, Dry Only, 400 Grit	5in / 125mm
3N-HP-5-0800	3N High Performance Pads, 5 Inch, Resin, Dry Only, 800 Grit	5in / 125mm
3N-HP-5-1500	3N High Performance Pads, 5 Inch, Resin, Dry Only, 1500 Grit	5in / 125mm
3N-HP-5-3000	3N High Performance Pads, 5 Inch, Resin, Dry Only, 3000 Grit	5in / 125mm
3N-HP-5-BUFF	3N High Performance Pads, 5 Inch, Resin, Dry Only, BUFF Grit	5in / 125mm

FLOOR MAINTENANCE

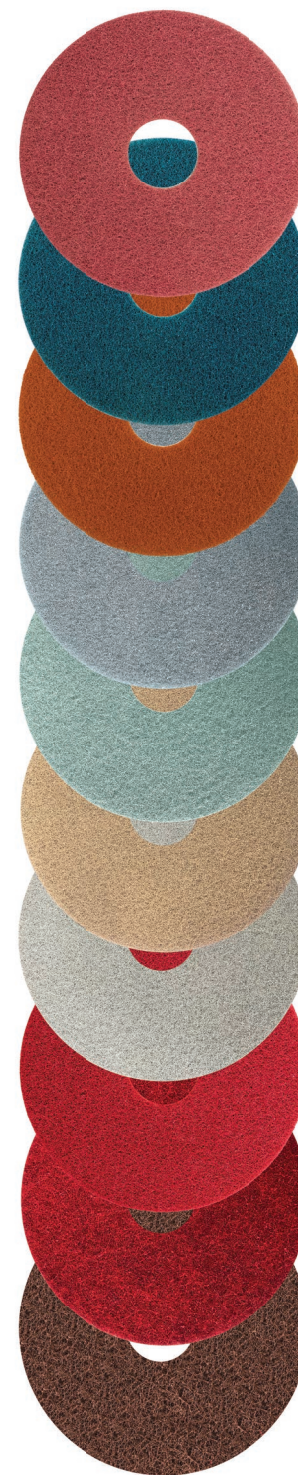

FLOOR MAINTENANCE

SUPRASHINE

THE MOST COMPLETE & EFFECTIVE TOOL RANGE FOR FLOOR RESTORATION AND MAINTENANCE



- ✓ Mechanical cleaning and polishing with diamond technology for long-lasting results.
- ✓ No chemicals required - use with water.
- ✓ Use with your standard cleaning machines (buffers, auto scrubbers, burnishers, etc).
- ✓ Cost-effective solutions that improve the bottom line for facility managers.

**SUPRASHINE
REGULAR PADS**

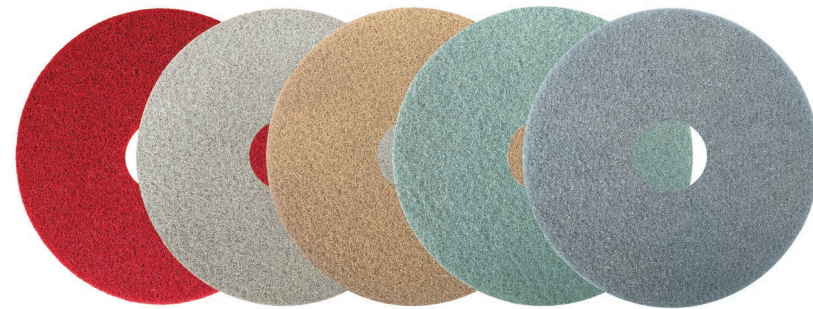

400 GRIT | 800 GRIT | 1800 GRIT | 3500 GRIT | 8000 GRIT

Professional range of pads with flexible material to deep clean, upgrade and maintain all types of coated and uncoated, hard and resilient floors.

Offered in all popular sizes from 5" to 28" diameter. Also available in rectangular shapes.

Item Number	Description	Size
SRG-0400-17	SUPRASHINE 400 GRIT, RED 17"	17 inch / 432 mm
SRG-0800-17	SUPRASHINE 800 GRIT, WHITE 17"	17 inch / 432 mm
SRG-1800-17	SUPRASHINE 1800 GRIT, YELLOW 17"	17 inch / 432 mm
SRG-3500-17	SUPRASHINE 3500 GRIT, GREEN 17"	17 inch / 432 mm
SRG-8000-17	SUPRASHINE 8000 GRIT, SILVER 17"	17 inch / 432 mm

Item Number	Description	Size
SRG-0400-20	SUPRASHINE 400 GRIT, RED 20"	20 inch / 508 mm
SRG-0800-20	SUPRASHINE 800 GRIT, WHITE 20"	20 inch / 508 mm
SRG-1800-20	SUPRASHINE 1800 GRIT, YELLOW 20"	20 inch / 508 mm
SRG-3500-20	SUPRASHINE 3500 GRIT, GREEN 20"	20 inch / 508 mm
SRG-8000-20	SUPRASHINE 8000 GRIT, SILVER 20"	20 inch / 508 mm

Item Number	Description	Size
SRG-0400-27	SUPRASHINE 400 GRIT, RED 27"	27 inch / 686 mm
SRG-0800-27	SUPRASHINE 800 GRIT, WHITE 27"	27 inch / 686 mm
SRG-1800-27	SUPRASHINE 1800 GRIT, YELLOW 27"	27 inch / 686 mm
SRG-3500-27	SUPRASHINE 3500 GRIT, GREEN 27"	27 inch / 686 mm
SRG-8000-27	SUPRASHINE 8000 GRIT, SILVER 27"	27 inch / 686 mm

**SUPRASHINE
HIGH PERFORMANCE**

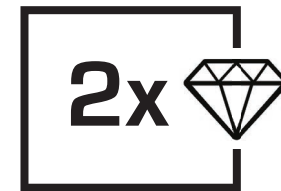
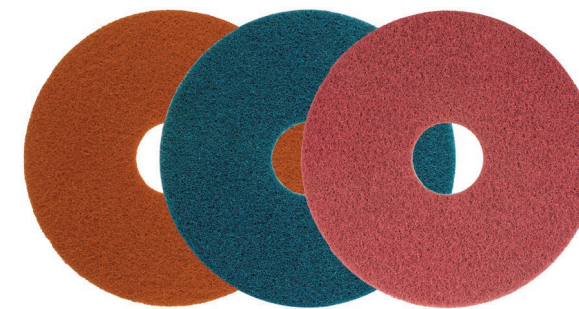

800 GRIT | 1800 GRIT | 3500 GRIT

A dedicated range of HIGH PERFORMANCE pads with flexible material for daily maintenance of HIGH TRAFFIC floors. Also, use to upgrade any floor during daily maintenance.

Offered in all popular sizes from 5" to 28" diameter. Also available in rectangular shapes.

Item Number	Description	Size
SHP-0800-17	SUPRASHINE HP 800 GRIT, ORANGE 17"	17 inch / 432 mm
SHP-1800-17	SUPRASHINE HP 1800 GRIT, BLUE 17"	17 inch / 432 mm
SHP-3500-17	SUPRASHINE HP 3500 GRIT, PINK 17"	17 inch / 432 mm

Item Number	Description	Size
SHP-0800-20	SUPRASHINE HP 800 GRIT, ORANGE 20"	20 inch / 508 mm
SHP-1800-20	SUPRASHINE HP 1800 GRIT, BLUE 20"	20 inch / 508 mm
SHP-3500-20	SUPRASHINE HP 3500 GRIT, PINK 20"	20 inch / 508 mm

Item Number	Description	Size
SHP-0800-27	SUPRASHINE HP 800 GRIT, ORANGE 27"	27 inch / 686 mm
SHP-1800-27	SUPRASHINE HP 1800 GRIT, BLUE 27"	27 inch / 686 mm
SHP-3500-27	SUPRASHINE HP 3500 GRIT, PINK 27"	27 inch / 686 mm

**SUPRASHINE
HEAVY DUTY PADS**



SupraShine HD tough material is ideal for surface preparation and chemical-free stripping with water only. Can be used with high-speed and low-speed machines.

Offered in all popular sizes from 5” to 28” diameter. Also available in rectangular shapes.

Item Number	Description	Size
SHD-0220-17	SUPRASHINE HD 220 GRIT, BROWN 17”	17 inch / 432 mm
SHD-0400-17	SUPRASHINE HD 400 GRIT, RED 17”	17 inch / 432 mm
Item Number	Description	Size
SHD-0220-20	SUPRASHINE HD 220 GRIT, BROWN 20	20 inch / 508 mm
SHD-0400-20	SUPRASHINE HD 400 GRIT, RED 20”	20 inch / 508 mm
Item Number	Description	Size
SHD-0220-27	SUPRASHINE HD 220 GRIT, BROWN 27”	27 inch / 686 mm
SHD-0400-27	SUPRASHINE HD 400 GRIT, RED 27”	27 inch / 686 mm

**SUPRASHINE
HYBRID TOOLS**

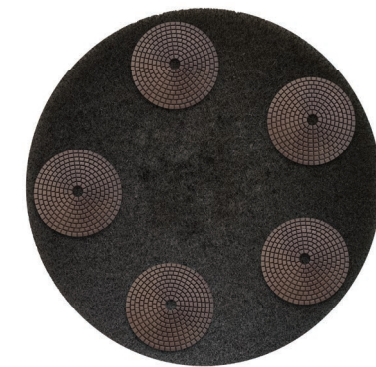

Attach the Hybrids to a non-woven pad

SupraShine Hybrids (5”) are designed to eliminate stains, scratches, and orange peel, restore and polish surfaces. Suitable for use on concrete, terrazzo and natural stone floors. Use with low-speed machines (recommended min. pressure 90-100 lbs) and water.

Item Number	Description	Size
SHB-050-5	SUPRASHINE HYBRID 50 GRIT	5 inch / 127 mm
SHB-100-5	SUPRASHINE HYBRID 100 GRIT	5 inch / 127 mm
SHB-200-5	SUPRASHINE HYBRID 200 GRIT	5 inch / 127 mm
SHB-400-5	SUPRASHINE HYBRID 400 GRIT	5 inch / 127 mm
SHB-800-5	SUPRASHINE HYBRID 800 GRIT	5 inch / 127 mm
SHB-1800-5	SUPRASHINE HYBRID 1800 GRIT	5 inch / 127 mm
SHB-3000-5	SUPRASHINE HYBRID 3000 GRIT	5 inch / 127 mm
SHB-BUFF-5	SUPRASHINE HYBRID 8000 GRIT	5 inch / 127 mm

ACCESSORIES

NEW! LAVINA FOAM PLATES

Quick Change magnetic plates with flexible foam and heavy-duty velcro for attaching velcro-backed tooling. Offered in 9" and 13" size for use with Lavina Grinders and Trowels (compatible with Elite & older models).

Item Number	Description	Size
LV9FPE	Lavina Foam Plate, 9 Inch	9in / 228mm
LV13FPE	Lavina Foam Plate, 13 Inch	13in / 335mm

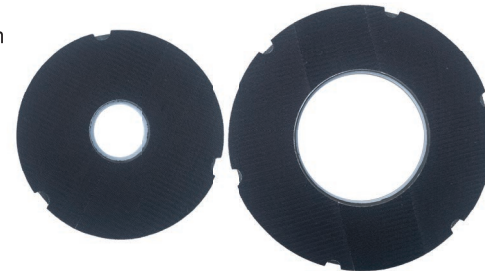

QUICK CHANGE ADAPTERS AND PLATES

You can easily use our Quick Change tooling with almost any other grinder on the market. We offer adapters and plates for HTC, Husqvarna, Edco, Scanmaskin, STI, Terrco, and other machines.

Item Number	Description	Size
XQC-HOLDER	QC tool holder adapter for bolting tools - universal bolt-on style	standard
X-HOLDER-STI	QC tool holder adapter for bolting tools to STI machines	standard
X-HOLDER-TER	QC tool holder adapter for bolting tools to Terrco machines	standard
QC-HOLDER-EDCO	QC tool holder adapter for bolting tools to EDCO machines	standard
XP-HTC-9	QC Plate for HTC500 & HTC650	9in / 230mm
XP-HTC-10.63	QC Plate for HTC800, HTC950, SASE6000 & 8000	10.63in / 270mm
XP-7-EDCO	QC Plate for Edco machines	7in / 178mm
XP-10-EDCO	QC Plate for Edco machines	10in / 254mm
XP-HUSQ-9	QC Plate for Husqvarna PG530 & PG680	9in / 228mm
XP-HUSQ-10.63	QC Plate for Husqvarna PG820 & PG950	10.63in / 270mm
XP-HUSQ-450	QC Plate for Husqvarna PG450	7in / 178mm
XP-Scanmaskin-8.4	QC Plate for Scanmaskin 650	8.4in / 213mm
XP-Scanmaskin-9.5-NEW	QC Plate for Scanmaskin 700/800/1000 new style (after mid 2016)	9.5in / 241mm
XP-Scanmaskin-9.5-OLD	QC Plate for Scanmaskin 700/800/1000 old style (before mid 2016)	9.5in / 241mm



Left to right:
Universal Bolt-on Adapter,
STI Adapter, Terrco Adapter,
Edco Adapter.



Left to right:
10.63-in QC Plate for HTC,
10.63-in QC Plate for Husqvarna,
10-in QC Plate for Edco,
9.5-in QC Plate for Scanmaskin.

ACCESSORIES

LIPPAGE HOLDERS

Great for attaching 3" and 4" velcro-backed tools on different machines.

Item Number	Description	Size
XQC-83-LH	Aluminum Lippage Holder, Quick Change style, 3 Inch	3in / 83mm
83LH	Aluminum Lippage Holder, 3 Inch	3in / 83mm
4LH	Aluminum Lippage Holder, 4 Inch	4in / 103mm



QUICK CHANGE PAD HOLDERS

Designed for attaching floor maintenance pads to Lavina tool holders.

Item Number	Description
XQCPH9	QC Pad Holder for 9 Inch Head (use 3 pcs per head)
A87.00.00R	QC Pad Holder for 13 Inch Head (1 pcs per head)



RUBBER SPACER WITH HOOK AND LOOP

Serve as a cushion between the diamond pad and the backer.

Item Number	Description	Size
RUB-SP-3	Rubber Spacer with Hook and Loop, 3 Inch	3in / 76mm
RUB-SP-5	Rubber Spacer with Hook and Loop, 5 Inch	5in / 125mm
RUB-SP-7	Rubber Spacer with Hook and Loop, 7 Inch	7in / 178mm
RUB-SP-9	Rubber Spacer with Hook and Loop, 9 Inch	9in / 229mm



BACKER PADS FOR ANGLE GRINDERS

Aluminum Backer Pads are suitable for Flat Surfaces or Straight Edges. Flexible Backer Pads are suitable for Corners and Curved Edges.

Item Number	EU Item Number	Description	Size
3AL-5/8-11	3AL-M14	Aluminum Rigid Backer Pad, 3 Inch	3in / 75mm
4AL-5/8-11	4AL-M14	Aluminum Rigid Backer Pad, 4 Inch	4in / 95mm
5AL-5/8-11	5AL-M14	Aluminum Rigid Backer Pad, 5 Inch	5in / 120mm
7AL-5/8-11	7AL-M14	Aluminum Rigid Backer Pad, 7 Inch	7in / 170mm
RB7in-5/8-11-FOAM	RB7-M14-FOAM	Flexible Foam Rubber Backer, 7 Inch	7in / 178mm

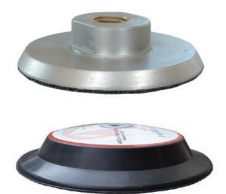

WARRANTY POLICY

A warranty registration must be submitted to Superabrasive (via mail, email or our web form) within 30 days of purchase in order for the following warranty to apply.

LAVINA Machines

LAVINA Grinding and Polishing Machines are covered by a 2-year or 600 operating hours warranty, whichever comes first, from the date of purchase, as invoiced by Superabrasive.

A complaint must be made to Superabrasive or a Superabrasive-appointed distributor or dealer within the warranty period, or the specified operating hours on the machine - whichever occurs first. A valid document confirming the date of delivery shall be presented at the time of the complaint.

In the event that a damage occurs and is reported within the **first 200** operating hours, Superabrasive will cover the shipping charges for transporting the machine to Superabrasive or an approved repair facility and back to the customer (within the contiguous 48 United States). Shipping charges must be agreed upon in advance and approved by Superabrasive. After the first 200 operating hours, the purchaser is responsible for shipping charges.

Superabrasive or a Superabrasive-appointed repair facility shall either replace or repair any defects, resulting from faulty design, materials, or workmanship. Products repaired or replaced during the warranty period shall be covered for the remainder of the original warranty period, or 90 days from date of the repair or shipment of the replacement, whichever is longer. Spare parts for repair will be either new or equivalent to new. Major components, such as inverters, electric motors, and engines installed at our facility on used machines outside of the original warranty period are covered for 1 year or 300 hours, whichever comes first. The warranty does not include normal wear and tear.

Superabrasive shall not be liable for any defects caused by circumstances that occur after the machine has been delivered, or defects caused by faulty maintenance, incorrect operation, faulty repair or alterations conducted without Superabrasive's prior written consent. The warranty is not applicable on a defect that arises due to tools or parts that are not original to Superabrasive.

The warranty herein is non-transferable, and only applies to the original owner or purchaser of the machine.

The Warranty is void if the purchaser has not followed the maintenance plan stipulated by the machine's manual. The warranty is void if the purchaser repairs said Goods himself, or if repairs are conducted by a repair facility that is not approved by Superabrasive.

Replaced defective parts shall be placed at Superabrasive's disposal and shall become property of Superabrasive. If such defective parts are replaced within 200 operating hours, the shipping charges will be covered by Superabrasive.

In warranty complaint cases, when no defects are found for which Superabrasive is liable, Superabrasive shall be entitled to compensation for the labor, material cost, and shipping charges, incurred by Superabrasive as a result of the complaint.

LAVINA Vacuums

LAVINA Vacuums are covered by a 2-year warranty from the date of purchase, as invoiced by Superabrasive.

Superabrasive agrees to repair or replace, free of charge, any parts which have failed due to manufacturer or material defects. Repairs must only be performed at authorized service facilities that have been approved by Superabrasive. Shipping and handling fees associated with warranty claims must be pre-paid by the customer / claimant. The following conditions pertain to this warranty:

- Applies only to the original owner and is not transferable.
- Vacuum must not be dismantled and tampered with in any way.
- This warranty does not cover any failures or defects caused by normal wear and tear, accidental damage, damage during transport, improper handling, repairs conducted by an unauthorized facility (without prior authorization by Superabrasive), or operation that is not in compliance with the instructions provided in this manual. Superabrasive denies all responsibility for damages or injuries, to any persons or objects, caused by improper operation of the vacuum unit.
- This warranty will become invalid in the event that equipment or accessories used on/with the vacuum unit are not supplied or approved by Superabrasive.
- Covered components proven defective will be repaired or replaced at no charge.
- This warranty does not apply to any repair of/to of proprietary parts, nor does it cover cleaning or general maintenance. This warranty does not apply to items with aftermarket alterations, changes, or modifications.
- This warranty is limited to repair or replacement of covered components and reasonable labor expenses.
- In the event of a warranty claim, the vacuum unit shall be returned to Superabrasive or an authorized facility, for a warranty investigation, and subsequent warranty repair or replacement.
- All warranty returns must be shipped freight prepaid.
- This warranty is in lieu of and excludes every condition of warranty not herein expressly set out and all liability for any form of consequential loss or damage is hereby excluded.

In the event that a warranty investigation determines that the damage or unit failure is not attributed to manufacturer or material defects, all costs associated with the repair of the vacuum will become the direct responsibility of the claimant. If payment is not rendered for such services, Superabrasive will assume ownership of the machine and any associated parts in possession.

Superabrasive does not authorize any person or representative to make any other warranty, or to assume for us any liability in connection with the sale and operation of our products.

Damaged Shipments

All shipments are carefully inspected before leaving our warehouse. If products are damaged during transit, be sure the driver acknowledges the damage on the delivery documents. If the driver does not acknowledge the damage on the documents, or if the said damage is not reported to the driver, damage costs may not be recuperated.

For more details, including return policy and business terms, visit superabrasive.com.

Headquarters and Sales Office, USA:

Superabrasive Inc.
9411 Jackson Trail Rd.
Hoschton, GA 30548, USA
TEL +1 (706) 658-1122
FAX +1 (706) 658-0357
TOLL FREE (800) 987-8403
EMAIL: info@superabrasive.us

Factory & European Sales Office, Bulgaria:

Superabrasive Ltd.
2A Rabotnicheska St.
6140 Krun, Bulgaria
TEL +359 431 64477
FAX +359 431 64466
EMAIL: factory@superabrasive.com

Superabrasive Turkey:

Superabrasive Ltd.
Yukari Dudullu Mah.Nato Yolu Cad.Sevinc Sk.#10
Istanbul, Turkey
TEL +90 216 450 3398
FAX +90 216 348 9598
EMAIL: info@superabrasive.com.tr

superabrasive.com

